



JOBS

Employ *Ability*
SUCCESS!

Essential Skills At Work



Employ*Ability*
SUCCESS!

**Essential Skills
At Work**

Acknowledgements

QUILL Learning Network is grateful for the support received through the “**EmployAbility Success! Essential Skills at Work**” Project, in particular, funding and support from the Ministry of Training, Colleges and Universities (MTCU).

The Network is most grateful for the hard work, focus and dedication of the paid contractors and the numerous stakeholders who contributed their time, expertise and in-kind resources.

Project Supervisor: Debera Flynn,
QUILL Learning Network Executive Director

Project Administrative Support: Karen Coutts, Debbie Scott

Writers: Karen Farrar, Sheila Marshall

Curriculum Reviewers: Judy Lalonde, Karen Morgan-Bowyer, Rose Strohmaier

Pilot Sites: We would like to sincerely thank and acknowledge all of the learners at each site, who piloted material and gave feedback, which helped to make this project a great success!

Pilot Site Staff: Collingwood Learning Centre, Claudia Stafford and Charlotte Parliament
PTP, Anne Marie Williams
Timmins Learning Centre, Timmins, Alison Koslow
Waterloo Region District School Board, Linda Brooks

Copy Editor: Tamara Kaattari

**Desktop Publisher/
Graphic Design:** Steve Knowles, The Right Type

Project Evaluator: Cindy Davidson, Davidson Communications and Training

Funder: This project is funded by the Ministry of Training, Colleges and Universities (MTCU).

All website links were valid at the time of publication.

Table of Contents

Introduction to EmployAbility Success!	1
MODULE 1 — Ready for Reading at Work	11
Practitioner Guidelines and Answer Key	12
Student Guidelines.....	27
CHAPTER 1 — Jerry Reads	29
CHAPTER 2 — Keith Reads	45
CHAPTER 3 — Erica Reads	67
CHAPTER 4 — Maria Reads	85
MODULE 2 — Ready for Document Use at Work	99
Practitioner Guidelines and Answer Key	100
Student Guidelines.....	115
CHAPTER 1 — Erica Uses Documents	117
CHAPTER 2 — Maria Uses Documents	129
CHAPTER 3 — Jerry Uses Documents	139
CHAPTER 4 — Keith Uses Documents.....	149
MODULE 3 — Ready to Use Math at Work	165
Practitioner Guidelines and Answer Key	166
Student Guidelines.....	181
CHAPTER 1 — Erica Uses Math.....	183
CHAPTER 2 — Jerry Uses Math.....	197
CHAPTER 3 — Maria Uses Math.....	207
CHAPTER 4 — Keith Uses Math	221

INTRODUCTION TO

EmployAbility SUCCESS!

Essential Skills At Work

Are you thinking about looking for a job? Are you interested in improving your Essential Skills for work? If so, this manual is for you. Here you will read about how Maria, Jerry, Erica and Keith improved their Essential Skills at the Centre for Upgrading and Employability Skills (CUES).

In this workbook you will **job shadow** Maria, Jerry, Erica and Keith, and learn how your Essential Skills can be transferred to the workplace. You will be learning some new skills and reviewing skills you already have.

Meet Four Students from CUES: The Centre for Upgrading and Employability Skills.

Meet Maria



Maria is 38 years old. She was married when she was very young, and now she has two children who are at college. When her children were younger, Maria was very busy driving them to activities and appointments as well as keeping her house and making meals for her family. But now her children go to their own appointments and activities. They take the bus or they go with their friends. They both have part-time jobs and they are not often home for supper.

Maria also enjoys volunteer activities. As a member of a pastoral care team in her church, Maria visits the sick and

the elderly. She sometimes takes them meals and helps them with a little tidying in their homes. Sometimes she reads the paper or a book to them, and sometimes she just visits. Maria commits about six hours per week to her volunteer work.

One evening Maria sat with her husband, Vince, at the supper table.

“I’m bored,” said Maria.

“Pass the tomatoes,” said Vince.

“I said I’m bored,” said Maria in a slightly louder voice. She held the dish of tomatoes, waiting for her husband to look at her.

“Oh. Why don’t you visit your sister?” asked Vince as he eyed the tomatoes.

“I did that last month. And, before you suggest it, I visited Nick and his kids the month before.”

Maria, now that she was sure that she had Vince’s attention, put the tomatoes down in front of him.

“So what do you want to do?” Vince asked.

“I want to get a job,” said Maria.

Vince blinked. A job!

“Why do you want a job? You don’t need to work,” he said.

“I want to do something different, Vince. I want to get out of the house more. I think I want to help people,” said Maria.

“So what do you want to do?” Vince asked again.

“I don’t know. I don’t know what I **can** do,” said Maria. “Today I was shopping downtown, and I saw a sign in a window that said **Employment Ontario**. I went into the office and made an appointment to speak to someone about work tomorrow.”

Vince nodded. He was not sure that he wanted Maria to get a job. He liked her to be at home. But lately he had noticed that Maria was not so happy. Vince remembered a time when he was off work for eight weeks because of a broken wrist. At the end of the eight weeks he thought that he would start climbing the



walls, he was so bored. He had been grumpy and irritable. The whole family celebrated his return to work. Maybe, thought Vince, that's how Maria is feeling.

So Vince said, "Good idea. See what they have to say." And he finished his tomatoes.

The next day Maria arrived at the office where she had seen the **Employment Ontario** sign. Now she saw that the place was called CUES — The Centre for Upgrading and Employability Skills.



"I'm not sure I'm in the right place," said Maria. "I'm looking for a job."

"I'm sure that we can help you get started," said Diane, who was the Executive Director of CUES. "Why don't you tell me what kind of work you are looking for?"

Maria told Diane about her desire to get out of the house more and help people.

"Are you thinking about nursing?" asked Diane.

Maria said, "My son is studying to become a nurse. I know that he is taking science at college. But I don't want to go to college. I have a friend who has someone come in and help her with her daughter, who needs a lot of care. I know that she didn't have to go to college because I asked her."

Diane nodded. "It sounds like she is a home support worker, although I am surprised that she has not been to college. That's a great job if you like helping people. We can assess your skills and figure out whether you are ready for this kind of work or if you need to do some upgrading first."

It had been a long time since Maria had been to school. She had forgotten many things. As well, she had moved to Canada as a young adult. She spoke English well, but it was not her first language.

Diane said to her, "You would really benefit from taking some upgrading and working on your Essential Skills. Then I am sure you will be ready for a job in home care."

Meet Jerry



Jerry is about fifty years old. For many years he worked in mining. He liked his job and almost never took any time off work. One day he had a bad fall in the mine shaft. He landed on his back and had to take over a month off of work. After x-raying his back, the specialist told him that he would not be able to work in the mine. He would have to find a new career.

Jerry's boss tried to help him find a new job in mining. He suggested that Jerry might like to work in mine safety, but Jerry said no. Jerry was too embarrassed to tell his boss that his reading was not good enough for understanding the safety manuals he would need to study to work as a safety officer.

Jerry received a pension because of his injury, but he wasn't happy. He liked to keep busy. Staying home was boring, and all of his friends worked all day. He began to feel very depressed. His worker suggested that he try CUES to upgrade his Essential Skills for work.

"Why not?" said Jerry, "Better than sitting around the house all day."

Jerry studied at CUES for about a year. All of his Essential Skills improved. He was especially proud of the fact that he learned how to use a computer. Now he uses a computer at home and on the job at Swift Auto Parts.

Meet Erica



Erica started upgrading at CUES when she was 18, but quit after she got pregnant. She returned to CUES when her little girl was two and she made a lot of progress in the time she was there.

When Erica thought that she would like to get a job, she had only ever worked in child care. Now that she had her own daughter, she wanted to do something else. Erica did not make enough money babysitting to support herself and her daughter. She did not always want to be on Ontario Works.

The trouble was, Erica did not know what she could do. She had never worked outside of her home, and she did not know what kind of job she might be good at. She

wanted to talk to her instructor, Lisa, about this problem, so she stayed behind in the classroom after everyone else had packed up their books and left.

“Lisa, could I talk to you for a minute?” she asked shyly.

“Sure you can, Erica. What’s up?” said Lisa.

“I’ve been thinking I’d like to get a job,” said Erica in her soft voice.

“That’s great to hear. Your work here has been excellent. I’m sure you can find something you would like to do. Do you have any ideas?” said Lisa.

“Not really,” said Erica.

“That’s all right,” said Lisa cheerfully. “I’ll give you a good website to check out. It may help you discover what it is you would like to do.”

Erica smiled. When she first started at CUES she hadn’t even known how to turn a computer on! Now she loved to surf the net and find interesting sites on parenting and children. She emailed photos of her daughter to relatives and chatted with friends on Facebook. Now the computer was going to help her find out about work, too.

(Log on to the site that Erica used to help her discover more about the kind of work she wanted to do. Do some of the quizzes to help you discover more about your work strengths, interests and abilities.)

www.jobsetc.ca/toolbox/quizzes/quizzes_home.do?lang=e

For more help with finding an occupation, go to **Ontario Skills Passport** at skills.edu.gov.on.ca/OSPWeb/jsp/en/introduction.jsp

Click on ‘**Create a Transition Plan**’ and follow the instructions.

It didn’t take long before Erica found some interesting occupations. She decided that she would like to work in a bakery. With extra practice on her **Communication Skills**, Erica was ready to apply for work. She found a job at Dough Dude Bakery.

Meet Keith



Keith was close in age to Erica, but he couldn't be more different! Erica had almost no work experience and Keith had too much. Keith had quit school when he was 16. Since then he had worked as a busboy, at a car wash, at fast food counters, and as a helper to some trades people. Keith's problem was that he could never keep any of these jobs. It seemed that either he got angry and quit or he was fired. Once he managed to keep a job in logging for a few months, but he was laid off before the end of the season. After that Keith had

gone on Ontario Works (OW). He had a few friends on OW too. Sometimes they would play pool together in the afternoon. One day Keith called his friend Pete to play pool.

"I can't," said Peter. "I'm going back to school."

"What?" Keith yelled into the phone. "Are you crazy? Why are you doing that?"

"I found out I can upgrade my math and then maybe get on as an apprentice at my uncle's construction company. I used to work for him in the summers and I really liked it. Anyway, I have to go. Maybe we can get together Friday night."

"Yeah, maybe," said Keith.

Keith didn't phone Pete that Friday night, but he saw him a few months later.

"Hey, how's it going?" asked Keith.

"Great!" said Pete. "I'm nearly finished my math upgrading at CUES and I will be starting work with my uncle in the spring."

"Cues? What's that?" asked Keith.

"I told you I was going back to school. Well, that's where I went. It's pretty good there — no kids and you can work at your own pace. You should try it!"

"Yeah, maybe," said Keith.

It took Keith a few more months to get up the nerve to check out CUES. The fact was that Keith had always hated school. He could remember the principal's office even better than his classroom. However, CUES was different. No one was telling him what to do all the time. This took some getting used to, but Keith found that he was pretty good at getting things done on his own.

After Keith had been at CUES for more than a year, he felt restless. He looked at the daily paper in class and checked out the employment ads. He saw some jobs that he thought he could do. But this time, Keith wanted a job he could keep. I'd like to work, he thought, but I don't want some jerk telling me what to do all the time! Keith needed extra practice in **Working with Others**. But after he had worked on this and his other Essential Skills, he was ready for work at Straight Path Construction.

Important Information about Essential Skills

As you work through these modules, you will be practicing your Essential Skills for work, learning and life.

You have probably already heard about Essential Skills. If you haven't, you can visit the Essential Skills website at

www.hrsdc.gc.ca/eng/workplaceskills/essential_skills/general/home.shtml

Briefly, there are nine Essential Skills:

- ▶ Reading
- ▶ Document Use
- ▶ Numeracy
- ▶ Writing
- ▶ Oral Communication
- ▶ Working with Others
- ▶ Thinking
- ▶ Computer Use
- ▶ Continuous Learning

This workbook consists of three modules where you can practice and improve your Essential Skills of **Reading, Writing and Document Use**. Remember that essential is another way of saying **necessary**. Because you want to succeed at work, you will need these Essential Skills for whichever job you choose.

Essential Skills are Transferable

You may have heard that Essential Skills are **transferable**. What does this mean? Essential Skills can be transferred or taken with you to any job. Therefore, when you are working on your Essential Skills, you know that you will be able to use them beyond the classroom and in the workplace.

For example, right now, as you read this page, you are practicing an essential workplace skill. Reading for work is different than reading for pleasure. At work,

you often need to read to locate information. Right now, you are reading to locate information on Essential Skills.

Here is another way to reflect on your transferable skills. Think of your Essential Skills as tools. Essential Skills are similar to tools in a number of ways:

- 1 When you learn a new Essential Skill, you add a new tool to your tool box.

Before you began your job preparation, you may have had a few tools in your tool box. But every time you practice and master an Essential Skill, it's just like adding a new tool to your box. And remember, it's your tool box. It goes with you when you have completed your upgrading and training.

- 2 When you improve an Essential Skill, it's like learning how to use more features of a tool.

You will find that the more you practice, the better you will become at using Essential Skills. Imagine this: you need to drill a hole in the wall, so you buy a drill. But the more you use the drill and learn about it, the more features you discover. Soon you're using it for all kinds of jobs. Essential Skills are like this too. The more you learn and the more you practice, the more you use them and the easier they become.

- 3 Like tools, Essential Skills need to be used often so they don't become rusty.

If you've ever worked with tools, you know how important it is to keep them in good condition, usually clean and dry. Tools that sit around unused get rusty. Essential Skills are the same. You can keep your Essential Skills in good condition by using them often.

- 4 Essential Skills are carried with you, like a tool box.









Many of the activities you perform at home and at work involve using Essential Skills. For example, playing a board game with a child can improve your **Critical Thinking** skills. Making a to-do list for a busy Saturday is one way of practicing **Job Task Planning**. Think of the many activities you have performed at home or at work. When you have used Essential Skills, you take them with you and you can use them wherever they are needed.

So why is it important to know that Essential Skills are transferable? Because now you know that you have important skills for a new job. You are bringing Essential Skills with you that you have used at home and in your upgrading.

Icons in the Guide

As you work through these modules, you will notice the tool box icon where you will want to pay attention to the transferability of a specific skill. You will also be encouraged to reflect on the skills you already have that you bring with you to your job preparation and future employment.

Here is a summary of all the icons used in the guide:

ICON	Description
	Tool Box — pay attention to the transferability of a specific skill
	Workplace Know-How
	Overtime Activity
	Job Shadowing
	Job Search Strategy
	Questions to aid understanding
	JOB TASK in Reading Module number 1
	JOB TASK in Document Use Module number 2
	JOB TASK in Math Module number 3

EmployAbility SUCCESS!

MODULE 1

Ready for Reading at Work



CHAPTER	TITLE	PAGE
–	Practitioner Guidelines	12
–	Student Guidelines	27
1	Jerry Reads	29
2	Keith Reads	45
3	Erica Reads	67
4	Maria Reads	85

Practitioner Guidelines and Answer Key

Overview of Module One — READING

Module One consists of four chapters. All four chapters provide students with opportunities to practice and improve the Essential Skill of reading. In each chapter, the students will encounter the following:

- ▶ A pre-assessment which allows students to rate their skills for specific reading-related tasks
- ▶ A scenario involving one of the four characters in the curriculum. Each character will work on different job-related reading activities
- ▶ Instructional text and practice activities, some of which will require access to the Internet
- ▶ Questions for reflection and discussion
- ▶ Overtime activities that provide additional practice
- ▶ A post-assessment that is linked to LBS and Essential Skills levels

The Essential Skill activities are presented within the context of an entry-level job; however, the activities are in no way

restricted to those jobs. The various reading tasks are typical of many work settings and are intended to be equally relevant for students with other employment goals.

Before starting the module with your students, please read through the student chapters as well as the practitioner guidelines. Some activities may require advance preparation on the instructor's part.

Please allow time for the reflection and discussion portions of each chapter. Students should be encouraged to provide their own insights and questions, which will enable them to be actively engaged in their own learning.

The Workplace Know-How sections also provide opportunity for discussion. Students entering the workforce for the first time will encounter numerous practices that are common to many jobs. These sections will provide them with information on what they can expect when they are on the job.

Chapter-Specific Instructions and Answer Key

CHAPTER ONE — Jerry Reads

In Chapter One, students are introduced to Jerry who works at Swift Auto Parts. Jerry will be reading safety memos and bulletins. The chapter also provides an opportunity to discuss the importance of working safely.



JOB TASK ONE: Reading Randy's Memo

When reading the memo, it's a good idea to point out the different sections of the memo and the importance of reading the headings first.

- 1 Students will likely provide a variety of answers. The main point they should mention is that the memo is not well-organized. It is written as one paragraph instead of in easier-to-read sections. The title of the memo is misleading as well.
- 2 Keeping the floor area clear and clean
 - a) keep floor in the back room clear of boxes
 - b) mop and bucket should be put away in the closet after each use
 - c) do not leave the ladder out when you are finished using it
- 3 Randy also included safety instructions on safe lifting.
- 4 D is correct.
- 5 Jerry also has to read the WSIB fact sheet and the safe lifting bulletin before signing Randy's memo.



JOB TASK TWO: Reading the WSIB Bulletin

The WSIB bulletin is easier to read because it is divided into sections, using titles. The use of bullets also makes it easier to read and understand. WSIB bulletins may be well organized but they often contain vocabulary which might be quite challenging for students. You may wish to work on the difficult words together.

- 1 Workplace Safety and Insurance Board
- 2 One in every five lost time injuries in Ontario is caused by a fall.
- 3 The answer to this is found in Step One where the key words in the title are **prevent falls**.
 - a) Correct housekeeping hazards
 - b) Correct conditions that can cause hazards
 - c) Provide, maintain and properly use equipment to help avoid falls
 - d) Provide, maintain and properly wear personal protective equipment
 - e) Establish safe work practices

4 The answer to this question is found in Step Two.

Randy needs to assess fall hazards and set standards and expectations:

- ▶ Do a detailed inspection of work areas
- ▶ Have trained individuals observe worker behaviour
- ▶ Investigate near misses
- ▶ Interview workers
- ▶ Review records of previous slips and falls
- ▶ Set workplace standards and expectations

Useful information is also found in Step Three, but it is less specific as it deals with setting expectations around safety and creating a safe work culture. It also mentions the importance of having proper policies in place and providing staff training.



JOB TASK THREE: Reading the Safe Lifting Bulletin

- 1
 - a) awkward, sustained posture
 - b) forceful exertions
 - c) repetitive movements
- 2
 - S — Spot the hazard
 - A — Assess the risk
 - F — Find a safer way
 - E — Everyday
- 3
 - a) ready the worker for training
 - b) exhibit and explain
 - c) observe and examine
 - d) monitor the worker
- 4 Answers will vary for this question. The point the bulletin makes is that using a back belt does not necessarily prevent injuries. It can provide workers with a false sense of security. The most important point is to use proper lifting techniques and to not rely on a back belt to protect you.



Overtime Task: Reading the WHMIS Training Memo

- 1 All new employees
- 2 WHMIS Training/Testing
- 3 New employees need to know the time and place of training. They also need to know that this training is mandatory and that resource information will be provided

to them. If they have difficulty answering all the questions, they will be given the opportunity to rewrite.

All of the information listed should be highlighted.

CHAPTER TWO — Keith Reads

In Chapter Two, students meet Keith who is an employee of Straight Path Construction. Keith is reading policies and procedures and a new worker orientation document. Policies and procedures can be quite challenging to read and understand. You may choose to gather additional samples of policies and procedures as many policies are fairly standard in the workforce such as harassment, hiring practices, and dismissal procedures. Practitioners could also share their own workplace policies, if appropriate.

As well, students should be made aware of the Employment Standards Act and a copy should be obtained, if possible, before beginning this chapter.

Stress the importance of reading any documentation carefully before signing — and that it is okay to ask for clarification when necessary.



Job Search Strategy #1: The Hidden Job Market

Encourage students to use Google to find an article on the **Hidden Job Market**.

Workopolis.com has a series of articles on this topic. www.workopolis.com/work.aspx?action=Transfer&View=Content/Common/ArticlesDetailView&lang=EN&articleId=m4s20070122File1Article1

Okanagan College also has useful strategies for job hunters, including information on the Hidden Job Market. www.okanagan.bc.ca/administration/students/coop/Resources__Links/Job_Hunting_Tips/The_Hidden_Job_Market.html

Students will have a variety of suggestions on how to tap into this market. Answers might include:

- ▶ talk to friends, family, teachers, acquaintances
- ▶ drop off resumes to places where you would be interested in working (most jobs are not advertised)
- ▶ check out employment services agencies. They often hear about jobs directly from employers. They also have information about grants and job subsidies.



JOB TASK ONE: Reading New Worker Orientation

- 1 Timesheets, Absentee Reporting, WSIB
- 2 Paperwork/Purchases, Garnishment of Wages and WHMIS
Paperwork/Purchases and WHMIS are most relevant to supervisors. Keith, as a new employee, would not be responsible for these. The garnishment of wages is only relevant if a court has ordered the taking of wages for a debt that is owing.
- 3
 - a) Timesheets are to be handed in by Monday at 5:00. If this is not done, your pay cheque could be delayed.
 - b) It is important to record your absences so that you and your employer have an accurate record.
 - c) Your signature and your supervisor's signature
 - d) You must contact the office before 8 am.
 - e) You must contact the office every day you are absent. If you are absent for two or more days, you will need a doctor's note when you return.
 - f) You must notify your supervisor immediately.
- 4 Keith should not sign the New Worker Orientation until he has also read the Health and Safety Policy and Program.



JOB TASK TWO: Reading the Health and Safety Policy and Program

As this is a longer document some reassurance may need to be given to students that they can get through it all. A long document offers the opportunity for students to practice the reading strategies they need in order to understand the relevant policies and procedures. Point out to students the use of headings, bolding, illustrations, etc. Encourage them to use highlighters for key information. Point out to students the importance of keeping a copy of this type of information. Once on the job, they may need to refer to it from time to time.

To make it easier for students to refer to the document when answering the questions, it might be useful to keep the health and safety document separate from the rest of the chapter.

- 1 In Section One, Keith needs to read the part entitled Workers/Employees. The other information is intended for management staff.
- 2 In Section Two, Keith needs to know that he is expected to be aware of any environmental impacts associated with his job. He also needs to know that he will be trained in this area.
- 3 All injuries, even slight ones, must be reported to your immediate supervisor before leaving at the end of your shift. You must contact the office every day to inform the office of your availability for work due to your injury.

4 If a serious injury occurs, do the following:

- ▶ Take command
- ▶ Provide protection
- ▶ Give first aid
- ▶ Call an ambulance
- ▶ Guide the ambulance
- ▶ Get the name of the hospital
- ▶ Advise management
- ▶ Isolate the accident scene

Discussion on the advantage of having first aid training to put on your resume might result from this question. It also provides an opportunity to discuss other qualifications that enhance employability.

5 Disciplinary actions that will be taken if you violate health and safety procedures:

- ▶ The first time the employee receives a verbal warning. The supervisor will discuss the violation and it will be fully documented.
- ▶ The second time the supervisor will review violation, and usually the employee will receive a suspension (usually 2 days without pay) and it will be documented.
- ▶ The third time management will decide on action — usually termination.

6 Safety meetings are held weekly. New employees are given a safety orientation upon hiring.

7 New Workers Orientation:

- ▶ Explanation of project and duties
- ▶ Review and issue a copy of the company policy and program
- ▶ Review of the procedure for reporting of accidents, WSIB forms and contact numbers
- ▶ Review timesheets, absenteeism reporting
- ▶ WHMIS training and fall arrest training

They will also receive site-specific orientation which includes the location of safety and emergency equipment, safety and environmental hazards and the location of the lunchroom.

8 Keith will need WHMIS training and fall arrest training.

CHAPTER THREE — Erica Reads

Chapter Three provides students with an opportunity to learn and use the skills necessary to read longer documents. They will also learn some useful strategies for studying for a test.

Workplace Know-How



This chapter provides an opportunity for instructors to discuss the importance of ongoing training. Employers value employees who are willing and able to upgrade their skills. On-the-job training is often in the form of a multiple choice test as is the case for WHMIS, NORCAT, Food Handler's Course, and Basic First Aid and so on. Knowing how to prepare for and take these tests will increase your students' chances of future success.



JOB TASK ONE: Reading a Table of Contents

- 1 Safe Food Handling** is likely to be the easiest for Erica as she has already been handling food while serving customers at the bakery. Her employer has already given her on-the-job training in this.
- 2 Foodborne Illness** is likely to be challenging for Erica as she has not had training on the different micro-organisms which cause disease and infection. This topic is more scientific whereas safe food handling and cleaning the premises involve a lot of common sense knowledge.
- 3** Answers may vary but the highlighted sections are the areas in which Erica is least likely to have knowledge. The other areas could be checked off as Erica is likely already trained in personal hygiene and safe handling of food. She is also likely to be aware of proper cleaning of the premises.
- 4** The first chapter, Public Health Legislation and the Local Health Department
- 5** The fourth chapter, Food Premises Sanitation



Why is it a good idea to read the review questions first?

Reading the review questions first allows you to focus on that relevant information while reading.

Table of Contents

Public Health Legislation and the Local Health Department	3
The Health Protection and Promotion Act (HPPA)	4
Food Premises Regulation	5
By-laws	6
Role of the Local Health Department	7
Review Questions	8
Understanding Foodborne Illness (Food Poisoning)	9
Costs of Foodborne Illness (Food Poisoning)	10
Commonly Used Words	11
Understanding Micro-organisms	12
How Bacteria Grow	13
What Pathogenic Bacteria Need to Grow	14
What is Foodborne Illness (Food Poisoning)	16
Types of Foodborne Illness	17
Allergies and the Role of the Foodservice Industry	26
What to Do if Someone Reports a Possible Foodborne Illness	27
Review Questions	29
Safe Food Handling	30
Temperature Control	31
The Danger Zone	32
Cook Food Thoroughly	34
Defrost Food Safely	36
Cross-contamination	37
Handwashing	39
Handwashing Basins	40
Glove Use	41
Personal Hygiene	42
Hazard Analysis Critical Control Point System (HACCP)	43
6 Steps to a HACCP System	44
Review Questions	48
Food Premises Sanitation	49
Cleaning and Sanitizing	50
Machine Utensil and Dishwashing	51
Machine Dishwashing	52
Manual Utensil and Dishwashing	53
Manual Pot and Oversized Utensil Washing	54
Dishwashing by Hand	55
Housekeeping	57
Sanitary Facilities	59
Pest Control	60
Review Questions	62
Appendix	63



JOB TASK TWO: Reading Longer Documents

A completed chart should look similar to the one filled in below:

Microbiological Foodborne Illnesses				
Bacterial Infections				
Infection	Source	Food	The Disease	Prevention
Salmonella	Intestinal tract, feces-humans, animals	Meat, milk, eggs	6 to 72 hours after eating, diarrhea, cramps, vomiting	Proper handling, processing, storage, preparation
E coli	Intestinal tract, feces-humans, animals-especially cattle	Raw meats (beef, poultry, pork), unpasteurized milk, contaminated water	3 to 10 days after eating or drinking; bloody, watery diarrhea; cramps	Cook food thoroughly; proper hand washing; drink only pasteurized milk and safe water
Bacterial Intoxication				
Staphylococcus aureus	Nose, throat, hair, skin, hands and feces of humans and animals	Ham, beef, pork, poultry, potato salad, custard, cream sauces, puddings, fermented dairy products	30 minutes to 8 hours after eating, vomiting, cramps, diarrhea	Cook food thoroughly, good personal hygiene, hand washing
Bacillus cereus	Everywhere in the environment, especially the soil	Soups, custards, meat, poultry Chinese style foods, rice	Causes diarrhea—3 to 5 hours Causes vomiting—mild symptoms, 30 to 60 minutes	Cook food thoroughly, keep hot food hot (60 degrees C or more), keep cold food cold (4 degrees C or less)



JOB TASK THREE: Reading a Glossary

What did you notice about how the words are organized? Students should notice words are in alphabetical order. This makes it quick and easy to look up words. Students should practice locating some of the words they highlighted.



Is Erica right that multiple choice tests are easy? Why or why not?

Point out to students that multiple choice tests can be quite tricky. Sometimes it is “which answer is most correct.” Some choices are put in to trick the test taker. It is true however that multiple choice tests allow you to “recognize” the right answer as opposed to coming up with it through use of your memory alone.

Take time to go over the strategies listed. Be prepared to share personal experiences.



Why do you think they are called districters?



JOB TASK FOUR: Answering Multiple Choice Questions

- 1 The answer is e, all of the above
- 2 The answer is c, vomiting
- 3 The answer is d, 6 to 72 hours after eating
- 4 The answer is d, all of the above
- 5 The answer is d, A and C



OVERTIME ACTIVITY

The overtime activities listed provide more detailed information on reading strategies and studying/test-taking strategies.

CHAPTER FOUR — Maria Reads

Chapter Four focuses on reading activities that will help students prepare to look for work. The tasks in this chapter will help students to independently research the necessary skills, qualifications and responsibilities for jobs.

This chapter will introduce them to Service Canada’s National Occupational Classification (NOC) codes and the Essential Skills Profiles. Students will be given the opportunity to read about the skills required for a job of their choice. They will then compare this information with the skills they currently have. Students will also consider the skills and qualifications that employers are looking for.

The tasks required for this chapter are quite challenging. Students are asked to compare the information from the NOC code, the Essential Skills Profile and a job posting. They will need to interpret and integrate information from three different sources. For many students working at a ES Level Two, this will require them to use ES Level Three reading skills. They will likely need some guidance and tutor support while working on the activities in Chapter Four.

The tasks in this chapter will be more manageable if students already have some knowledge of the skills required for their chosen occupation. The Job Bank website, part of Service Canada, has a good section on career quizzes that students might like to investigate.

http://www.jobsetc.gc.ca/toolbox/quizzes/quizzes_home.do?lang=e

Students will need access to the Internet and a printer to complete all the activities in this chapter.



JOB TASK ONE: Finding and Reading NOC Codes

Students must find and print out the NOC code information for Maria’s job as well as a job they are interested in. The key information to highlight will be found under Main Duties and Employment Requirements.



JOB TASK TWO: Finding and Reading Essential Skills Profiles

The tasks in an Essential Skills Profile are listed, starting with most typical and ending with most complex.

1 The Profile with the completed highlighting should look like this:

Visiting Homemakers, Housekeepers and Related Occupations:

- ▶ read **memos** from members of the health-care team **and notes** from the client or the client's family. (1)
- ▶ may read **recipes** to prepare food which clients request. (1)
- ▶ read **newspapers and letters** to the patient. (2), (frequently)
- ▶ may refer to **orientation material** and regulations on **procedures, policies, behaviour and safety requirements** set forth by home care agencies or foster parent agencies. (2)
- ▶ read **newsletters** from social service agencies or associations announcing workshops. (2)
- ▶ read **reports** from agencies outlining policy changes. (2)
- ▶ may read **notes** from a foster child's **case file** about the child's background, medical history, mental health and special needs. (2)
- ▶ read **first-aid manuals**. (3)
- ▶ read **text books, pamphlets and journal articles** to learn more about health issues such as chronic diseases, mental disorders, exercise and nutrition. (3)

2 The two most important Essential Skills are Oral Communication and Problem Solving.

Oral Communication for Visiting Homemakers is inserted below with the key skills highlighted. The first four tasks are the most typical.

- ▶ may **contact medical staff** in emergencies. (1)
- ▶ may **talk with grocery store clerks, doctors, physiotherapists or suppliers of items such as walkers, canes and oxygen**. (1)
- ▶ may **discuss schedule changes, tasks and procedures with clients**. (1)
- ▶ may **talk with the client's family** to inform them of the client's progress and to learn about the client's condition and needs. (1)
- ▶ may **comfort clients** or foster children if they are upset. (2)
- ▶ may **entertain clients** by reading to them, talking to them or taking them on trips or visits. (2)
- ▶ may **talk to supervisors** to learn about courses, report on the progress and condition of clients and discuss new cases. (daily or monthly) (2)

Problem Solving for Visiting Homemakers is inserted below:

- ▶ encounter a lack of food to cook proper meals. **They find what food they can and make the best of the situation or grocery shop for the patient**, reporting the incident to supervisors if necessary. (1)
- ▶ **determine why clients are upset and calm them down**. This is particularly difficult when working with mentally challenged clients. (2), (frequently)

- ▶ may encounter resistance from clients who refuse to eat, take their medication or bathe. They explain the importance of keeping up with the necessities of life and use humour to make the clients feel more relaxed and willing to co-operate. (2)
- ▶ may encounter problems setting boundaries and defining roles with a client. They explain in detail the parameters of their job and may call upon agency personnel to reinforce the information. (2)
- ▶ may deal with hostile patients. They call upon family members or doctors to get to the roots of the hostility and to recommend a solution. (2), (occasionally)
- ▶ may contend with medical emergencies. They may call an ambulance if the case is too serious for them to deal with. (3), (occasionally)

3 The answers will vary depending on the job chosen by the student.



JOB TASK THREE: Comparing the NOC, Essential Skills and Job Ads

The completed chart should look similar to the one below.

NOC Information: Main Duties	Most Important Essential Skills	Skills Exper. Job Ad 1	Skills Exper. Job Ad 2
Care for individuals and families during periods of incapacitation, convalescence or family disruption	Oral Communication	One year personal care experience	Experience an asset
Administer bedside and personal care to clients such as aid in ambulation, bathing, personal hygiene, and dressing and undressing	Problem Solving	Communicate verbally, writing English, Spanish knowledge an asset	Speak, read, write English; speak Italian; Spanish, Portuguese an asset
Plan and prepare meals and special diets, and feed or assist in feeding clients		Work independently and as a team, excellent interpersonal skills	
May perform routine health-related duties		Follow written and verbal instructions	Reading Text, Document Use, Numeracy, Oral Communication
May perform routine housekeeping duties		Assist clients with standing, sitting walking...	Light housekeeping, cleaning, meal preparation; assist clients with walking, bathing and personal hygiene
		Knowledge of community nursing and personal care	
		Personal support worker certificate or health care aide certificate	Completion of high school, first aid certificate, health care aide certificate etc.

The second part of this activity has students seeking out the same information for their own job interests as Maria did in the scenario. Students may not have only one job goal. They can choose any job that they are interested in; however, they should be encouraged to choose entry-level jobs so that the activity is more realistic.

This is a challenging activity; students must integrate all the information from four sources. Allow for plenty of time. Encourage students to use a highlighter for key information. Explain to them that similar information may be worded slightly differently from job ad to job ad.



OVERTIME ACTIVITIES

The overtime activities include excellent websites. They will be especially helpful for students who may not have a clear employment goal. They are also useful for students who want to assess their Essential Skills Levels and set up a training plan which will outline what they need for specific jobs.

Module 1 — Student Guidelines

Ready for Reading at Work

All jobs require some reading skills. For example, you may have to read safety information, memos, notices, or policies. Many jobs have similar reading needs. In this module, you will see that Maria, Jerry, Keith and Erica all need to do reading for their jobs. Even though you may not be seeking the same jobs as Maria, Jerry, Keith and Erica, you will need to perform the same or similar reading tasks. Reading is an Essential Skill for work and all **Essential Skills** are **transferable** from job to job. When you practice the reading activities in this module, you will be improving your reading skills for whichever job you wish to apply for.

While this module focuses on reading, you will also be practising other Essential Skills. When you are on the job, you are often required to perform a number of skills when you are given a specific task.

Jerry reads important safety information at his workplace. His co-worker, Reg, had an accident at work. Jerry's boss decided that he would ask his employees to review safety guidelines. He wanted to prevent future accidents and Workers' Safety Insurance Board (WSIB) claims.

Maria will be reading information about personal support workers and home care. She will be reading job descriptions and

employment ads as she gets ready to prepare her résumé and covering letter. Most people who are searching for work need to learn these kinds of reading skills. Learning to read job descriptions and employment ads is a transferable skill.

Keith is employed at Straight Path Construction. He needs to read his employer's rules and policies around work. When you get a job, you are responsible for reading and knowing your employer's policies and procedures. Reading policies and procedures is a transferable skill.

Erica is working at Dough Dude Bakery. In this chapter, Dough Dude is visited by the health inspector. Erica needs to read through a lot of food safety information for her work. Food safety is enormously important, and anyone working with food and serving the public needs to know the basic standards around food handling. Employees who do not work in the food industry usually need to learn other safety practices for their work. Reading safety information is a transferable skill.

Are you ready for reading at work? Read the scenarios and do the activities that follow. They will help you to improve your reading skills for the job you want.

CHAPTER 1

Jerry Reads

Rate yourself on the skills employers want.

Employability Skills	I have this skill.	I am not sure.	I need to work on this skill.
I am able to read and understand workplace memos.			
I am able to read and understand WSIB safety information.			
I can read and understand safety information.			



Job Shadowing: Reading Memos and Bulletins

Jerry pulled into a parking space at Swift Auto Parts. He was feeling very relaxed after a week’s vacation, and, at the same time, he was looking forward to being back at work.

As he locked his door, Randy, the franchise owner of Swift Auto Parts, pulled up beside him.

“Hi Jerry, how was your vacation?” asked Randy.

“Great, thanks,” said Jerry. “How is Reg? I heard he had an accident. What happened?”

“He tripped over a box and fell. Fortunately, he just sprained his wrist. He should be back at work in another two weeks,” said Randy.

They walked into the building together. Randy headed for his office and Jerry went into the back room. It was a large room where auto parts were organized in long rows of tall shelves. There was also a counter against one wall where they did their shipping and receiving. In one corner of the store room there was a fridge, a table and chairs. There was also a large bulletin board. Randy would tack up the schedule here and any other notices he wished the staff to read.

Workplace Know-How



Most workplaces have an accepted way for management and staff to communicate. It can be a bulletin board, a log book or an in-basket. When there are different shifts working, it is often the only way to keep informed about what is happening. It should always be checked at the beginning of a work shift.

Jerry scanned the bulletin board. He wasn't surprised to see a few new memos related to workplace safety. One was written by Randy. The others looked like fact sheets about preventing workplace accidents. Jerry read the one from his boss first.

When he had finished reading it, Jerry blinked. Mops and buckets? Ladders and WHMIS? What was the memo about? Jerry decided to read it again. He did not want to write his initials at the bottom of the memo (as Randy had requested) without understanding it first.



JOB TASK ONE: Reading Randy's Memo

Read Randy's memo and answer the following questions.

- 1 Why do you think that Jerry finds the memo confusing?

Swift Auto Parts

Memo

To: All Staff
From: Randy Spenser
CC: John van der Kraft, head office
Date: 12 May 20__
Re: Workplace Safety – keeping the floor area clear and clean

In order to prevent any more accidents on the job, please make sure that the floor in the back room is kept clear of boxes. The mop and bucket should be put away in the closet after each use. If you have mopped the floor, please put up the wet floor sign. Use the step ladder for reaching for parts above the 5th shelf. Place the ladder in front of the section you need to reach. Move the ladder if you need to reach another section. Do not leave the ladder out when you have finished with it. If you need to move any heavy boxes, refer to the safe lifting information. Sign the bottom of this memo to indicate that you have read and understood both the safe lifting bulletin and the WSIB bulletin.

Randy

Initial here to show that you have read and understood this memo and that you have read the WSIB and safe lifting bulletins.

RS MG

Randy has given his staff a lot of information, but it is not well-organized. Jerry decides that he needs to organize the information in order to understand it.

First Jerry notices that Randy has written a memo, which is short for memorandum. With memos, there is usually a line that reads Re: which is short for regarding. Regarding just means “what the memo is about.”

2 What is this memo regarding?

Now Jerry knows to look for safety information regarding keeping the floor area clear and clean.

3 List the instructions that Randy has given to keep the floor area clear and clean.

4 Has Randy included any other safety instructions? What are they?

5 Randy’s memo says “Re: Workplace Safety — Keeping the floor area clear and clean.” Is this an accurate description of what is included in this memo? Choose a better description from the options below.

Randy’s memo is:

- a) Re: Ladder Safety
- b) Re: Safe Lifting
- c) Re: Slips and Falls
- d) Re: Slips and Falls and Safe Lifting

Jerry read the memo a third time. Good. He had read and understood all of the safety information in the memo. Could he initial the memo? Not yet, Jerry thought.

6 What else does Jerry have to do?



JOB TASK TWO: Reading the WSIB Fact Sheet Bulletin

Scan the WSIB Fact Sheet Bulletin in order to perform the following tasks.

The title, **Slips and Falls**, gives the reader accurate information about the bulletin. Highlight the title.

The bulletin includes a small **pie chart** that gives the reader a visual understanding of injuries related to slips and falls. Highlight the pie chart.

The bulletin uses three steps in bold to describe how you can prevent slips and falls. Highlight the three bolded steps.

Now that you understand how the information is organized in this bulletin, read it and answer the following questions.

1 What is WSIB short for?

Jerry could see why Randy had posted a bulletin on slips and falls. Clearly, many accidents at work were caused by slips and falls.



Workplace Safety &
Insurance Board

Commission de la sécurité
professionnelle et de l'assurance
contre les accidents du travail

ENGLISH

Fact Sheet

Prevention

Slips and Falls

Slips and Falls

- In 2000 to 2001, 20 workers died falling at work.
- One in every six lost time injuries (LTI), in Ontario, is caused by a fall.
- 80 people are injured every day in a fall at work, that's one every 20 minutes.

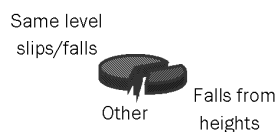

Same-level slips and falls account for 65% of all fall injuries

Falls from heights account for 34% of all fall injuries.

Steps to reducing fall hazards

Step One: Recognize that you can prevent falls and identify where the potential for them exists.

Slips happen when there is too little traction between footwear and the walking surface or walking surfaces are irregular. Falls occur from one level to a lower level. People have made WSIB claims for falling over a hose on the floor, from a lift truck, down stairs, off a loading dock, from a two-foot high stool, while climbing a dumpster and from 38 feet while climbing a ladder. Take preventive measures even on small or short duration jobs.

Correct housekeeping hazards.

- ◆ wet or oily surfaces
- ◆ occasional spills
- ◆ loose, unanchored scatter rugs or mats
- ◆ clutter
- ◆ obstructions

Correct conditions that can cause hazards.

- ◆ flooring that is slippery or has irregular surfaces, (ridges, steps, thresholds)
- ◆ hazards caused by weather conditions
- ◆ poor lighting or visibility
- ◆ open manholes or openings in floors due to construction or repairs being done in buildings

Provide, maintain and properly use equipment/devices to help avoid falls

- ◆ ladders
- ◆ scaffolds
- ◆ guard rails and barriers even on temporary worksites
- ◆ man lift equipment

Provide, maintain and properly wear personal protective equipment (PPE)

- ◆ Fall arrest
- ◆ Other PPE should not pose a visibility hazard

Establish safe work practices

- ◆ Pace of work
- ◆ Proper use of PPE
- ◆ Complete training



Step Two: Assess fall hazards and set standards and expectations

Assess the degree of risk of the suspected or identified fall hazard, by

- doing a detailed inspection of work areas
- having trained individuals observe worker behaviour
- investigating ‘near misses’
- interviewing workers
- reviewing records of prior slips and falls, such as first-aid records or minutes of joint health and safety meetings
- setting or comparing to company and legal standards for slip/fall hazards

Every workplace should have workplace standards, expectations, and rules that consider industry and regulatory guidelines. All staff need to know about them and that they are enforced. This way a company has a baseline against which results of their ongoing assessments can be compared. When people maintain workstations and work areas at company standards, staff are trained in safe work practices, and staff are monitored to ensure they follow safe work practices, falls are preventable.

Step Three: Control hazards by eliminating or reducing risk

A company can control hazards if it

- sets an expectation that each worker has a role and responsibility to help prevent slips and falls
- communicates the expectation to all staff
- sets the highest standards for housekeeping, lighting and visibility standards
- identifies and reinforces the supervisor’s role to enforce standards
- ensures standards for preventing potential causes of slips and falls are met
- provides equipment that is in good repair and is used properly
- makes workers aware of slip and fall hazards
- trains workers how to avoid slips and falls, themselves and for other workers.

When it is impossible to eliminate a hazard and personal protective equipment is essential, you should:

- review regulations that apply to your industry and your company, ensuring that physical restraints, tie-off, working at height regulations and others are followed
- become informed on the availability of fall arrest equipment, the way to properly use it and how to maintain it
- prepare an emergency response plan that is specific to the worksite in the event a worker becomes suspended by their fall arrest equipment or in the event of emergency such as fire or weather conditions.

Workplace Safety and Insurance Board

Ontario’s Workplace Safety and Insurance Board (WSIB) plays a key role in the province’s occupational health and safety system. Funded by employers, the WSIB is one of the top 10 disability insurers in North America. In addition to a strong prevention mandate, the WSIB provides insurance for injuries and illnesses incurred in workplaces covered under the *Workplace Safety and Insurance Act* and supports early and safe return to work for injured workers.

For more information, contact the WSIB’s Prevention Hotline at 416-344-1016 or 1-800-663-6639. This information is available in several languages by calling our information hotline at 416-344-4999, toll-free 1-800-465-5606 or Telephone Service for the Deaf (TTY): 1-800-387-0050

2 How many lost time injuries are caused by slips and falls?

Jerry now knew that Reg's fall could have been prevented if they had kept their workspace clear of boxes. Looking around he could see other ways they could improve their housekeeping to ensure no one else took a spill.

3 List the five ways to prevent falls at work.

4 What does Randy need to do **as an employer** to keep his workers safe and to assess risks and hazards? Look for six items.

- 5 Even though the WSIB Fact Sheet Bulletin is longer than Randy’s memo, Jerry found it easier to read. Why?

Jerry made sure that he understood the WSIB Fact Sheet Bulletin before reading the Safe Lifting Bulletin. Then he initialled the memo from Randy. As he went back to work he was already thinking of ways to improve his work environment so that he would be safer on the job.



JOB TASK THREE: Reading the Safe Lifting Bulletin

Read the **Safe Lifting Bulletin** on page 39 and 40, and answer the following questions.

- 1 List the three lifting hazards.

- 2 What do the letters S. A. F. E. stand for?

- 3 Your boss has asked you to do lift training with a new employee. What are the four steps you need to follow?

- 4 Why do you think the bulletin contains information about “back belts”?

Workplace Know-How



Employers want workers who can work safely. Accidents cause injuries, but they also cause lost time on the job and a loss of money for the employer and the employee. Staying up to date with safety issues is essential for doing your job well.



**SAFE
WORK**



No. 246
October 2007

SAFE LIFTING

Back injuries are one of the most common workplace injuries in Manitoba, and may be long and painful to recover from. Unfortunately, suffering one back injury puts you at a greater risk of suffering another.

The most important thing you can do to prevent a back injury is to use proper lifting and material handling techniques. (If you are suffering back pain, contact your physician for more information.)

This bulletin discusses why back injuries occur, and how to prevent them.

Lifting Hazards:

- **Awkward / Sustained posture** - Improper lifting technique is the largest cause of lower back injuries. For example, bending at the waist, or twisting while holding anything greatly increases the stress on the muscles and joints of the back.
- **Forceful exertions** - There is a limit to the amount of weight the back can lift; this limit is different for each person. Know and respect your limits. Use mechanical aids wherever possible, i.e. cranes, carts, dollies, etc.
- **Repetitive movements** - Repeated actions cause fatigue; fatigue reduces the amount of weight the body can safely lift. Be sure to give the back adequate rest between lifts.

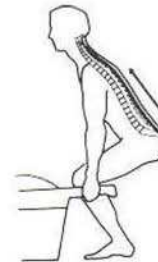

Preventing Back Injuries:

- Spot the hazard**
- What conditions prevent you from using safe lifting techniques?
 - Is the load heavy, awkward or hard to hold?
 - Is your back tired before the end of your shift?
- Assess the risk**
- Test the weight of the load before lifting
 - Is your back sore or tired before the lift?
 - Did you clear your path of obstacles and debris?
- Find a safer way**
- Always use good lift techniques
 - Never twist your back with weight in your hands
 - Use or ask for a mechanical lift
 - Ask for help with the lift
- Everyday**
- It is your right to be safe at work
 - Taking short cuts increases the chance you will be hurt
 - Think about lifting safely

BACK BELTS – CAUTION!

A back belt is a medical device and should be used under the direction of a health care provider. *In other words, the decision to wear a back belt is a personal choice not to be influenced by workplace parties.* (See more information on page 2)

Lift Training:

Employers have a duty under the Act to provide workers with information, instruction, training and supervision to ensure their safety and health on the job.

<p>Step 1: Ready the worker for training</p> <ul style="list-style-type: none"> • Obtain the focus of the worker • Determine the worker's current level of knowledge regarding lifting • Position the worker so they share your physical point of view as you are teaching the skill or procedure 	<p>Step 2: Exhibit and explain</p> <ul style="list-style-type: none"> • Show the worker each movement and procedure you expect them to know, step-by-step • Emphasize the important points, i.e. no twisting & lifting with the legs • Explain clearly and entirely
<p>Step 3: Observe and examine</p> <ul style="list-style-type: none"> • Require the worker to demonstrate each skill back to you along with a verbal explanation of the demonstration • Watch the worker's demonstration; comment on all effective and ineffective movements and/or procedures • Demonstrate for the worker again, if needed • Have the worker demonstrate again; continue this practice until the worker understands how, and is able to, carry out the task effectively 	<p>Step 4: Monitor the worker</p> <ul style="list-style-type: none"> • Explain where to receive further instruction • Allow the worker to perform the work unassisted • Review the worker's understanding after a few days or a week • Monitor the worker daily until you are confident the proper lifting techniques have become standard practice

Proper Lifting technique:

The following is for informational purposes only. No warranties or guarantees are made on the usage of this information.

<ol style="list-style-type: none"> 1) Test the weight of the load <ul style="list-style-type: none"> - If it feels too heavy ask for help, or use a mechanical lifting device - It is your legal right to refuse to lift anything you feel may be a danger to you 2) Position your body close to the load 3) Take a wide stance, with the load between the knees if possible 4) BEND YOUR KNEES 5) Bending at the waist should never be permitted <ul style="list-style-type: none"> - Never try to catch a falling load 6) Keep the lower back straight <ul style="list-style-type: none"> - The risk of injury increases when the lower back is rounded 	<ol style="list-style-type: none"> 7) Keep your head up, the more vertical your posture, the lower your risk of injury 8) Breathe out as you begin to lift <ul style="list-style-type: none"> - This increases tension in your abdominal muscles - Do not hold your breath during a lift; this increases pressure in the abdomen 9) Always keep your shoulders in line with your feet <ul style="list-style-type: none"> - Twisting significantly increases the risk of injury - Never twist while lifting or carrying anything, even light objects - NO TWISTING! 10) Proper lowering is as important as proper lifting <ul style="list-style-type: none"> - Dropping or throwing loads is hazardous - Bend the knees, keep the back straight, and breathe out as you begin to lower.
---	---

BACK BELTS – CAUTION!

<ol style="list-style-type: none"> 1. Back belts <u>are not</u> considered personal protective equipment. 2. The use of back belts <u>has not</u> been proven to reduce the risk of lower-back injury from repetitive lifting, bending, twisting, pushing or pulling. 3. Back belts <u>do not</u> significantly improve lifting capacity. 4. Back belts <u>have not</u> been shown to remind workers to use proper lifting technique. 	 <p>Sample of one type of back belt</p>
<ol style="list-style-type: none"> 5. Back belts <u>have not</u> been shown to cause workers to avoid heavy lifting. Manually handling heavy loads is known to increase the risk of injury to the lower-back. 6. Back belts <u>were not</u> originally designed for workplace injury prevention, but rather for medical rehabilitation purposes, and later adapted to specific weight-training applications. 	



OVERTIME ACTIVITY: Working with Memos

Read the memo on the following page and answer the questions below.

1 Who needs to read this memo?

2 What is this memo about?

3 What do new employees need to know about WHMIS training? Refer back to the memo and highlight the key pieces of information.

Swift Auto Parts

MEMORANDUM

TO: ALL NEW EMPLOYEES **DATE: AUGUST 7, 20__**

FROM: OCCUPATIONAL HEALTH & SAFETY SUPERVISOR

RE: WHMIS TRAINING/TESTING

Swift Auto Parts is committed to providing a hazard-free workplace for all our employees.

This is a “joint responsibility” under the provincial legislation introduced in 1978, Bill 70, of The Occupational Health and Safety Act. Joint means that the employer and the employee have equal *responsibility* and *accountability* to ensure a safe work practice. With this legislation, employees have the *right to participate* in their health and safety, i.e., through the Joint Health & Safety Committees as well as the *right to know* about the hazards in the workplace and safe workplace practices.

Further legislation in 1987, Bill 79, adds WHMIS to the Occupational Health & Safety Act. As an employee you are responsible to apply your knowledge to observe safe work practices at all times. You are also to work in compliance with the act.

Penalties can be issued for taking part in unsafe work practices. This can be to the employer and the employee. It is therefore mandatory that all employees participate in this training and respond to the accompanying questionnaire. Resource information is provided to you. If you have difficulty completing the questionnaire, you will be given an additional opportunity to rewrite the questionnaire and to attend further training on WHMIS.

Answer sheets are to be returned at the end of the WHMIS training session. Thank you for your cooperation and participation. Details of training are provided below.

Date: September 30, 20__

Time: 9 am

Place: Boardroom

Performance Review

In this chapter you have worked on essential reading skills for work. How do you think you did? Use the chart below to reflect on your improved ability to use reading skills for work.

Essential Skill	Exceeds Expectations	Meets Expectations	Needs Additional Training	LBS	ES
Reading					
I can scan for information.				2	1
I can skim for overall meaning.				3	1
I can read simple texts for several pieces of information.				3	2
I can interpret information from two different texts.				3	3
Other Essential Skills					
Document Use					
I can use text organizers (table of contents, titles, headings, etc.) to locate information.				2	1

CHAPTER 2

Keith Reads

Rate yourself on the skills employers want.

Employability Skills	I have this skill.	I am not sure.	I need to work on this skill.
I am familiar with the hidden job market.			
I know what workplace policies and procedures are.			
I can read and understand workplace policies and procedures.			
I can read and understand longer documents.			



Job Shadowing: Reading Policies and Procedures

Keith was having a hard time sleeping. He tossed around in his bed and pounded his pillow. Finally, he got up and got a glass of water. Back in his bedroom Keith checked (for about the fiftieth time) that his new steel-toed construction boots and blue hard hat were where he would not forget them.

Keith was starting a new job in the morning at Straight Path Construction. For the first time ever, he felt ready for work and excited about his new job. Keith had got the job through his friend, Pete. Straight Path Construction was owned by Pete’s Uncle Louie. As Keith lay in bed, he went over in his mind the events that had led to him getting the job.

Keith gets his job

“Hey, Keith, how’s it going?”

Keith turned around to find his friend Pete walking up behind him.

“Hey, Pete! Things are pretty good. How about with you?” said Keith.

“Great, thanks. I’ve been working with my Uncle Louie for about six months now. I’m working on becoming a heavy equipment operator,” said Pete proudly.

“That’s really good,” said Keith. He paused nervously. Keith had wanted to call Pete for over a month now. He wanted to ask Pete about getting him in at his uncle’s construction business. Now Keith took a big breath.

“Uh, Pete? You don’t know if your uncle needs any extra help, like for construction labourers?”

Pete looked surprised.

“Are you looking for work?” he asked.

“Yeah. You probably don’t remember, but after you told me about CUES, I decided to go and see what it was all about. I looked at a few jobs while I was there and decided that I wanted to work in construction.”

Pete nodded. He liked Keith, and they had had a lot of fun together playing pool. He just wasn’t too sure about Keith as a worker. He looked at Keith again. He looks serious about this, thought Pete.

“I could ask him,” Pete said slowly. “The thing is, are you sure it’s what you want to do? I mean, I’ll be talking to my uncle! I don’t want to stick my neck out if you don’t really want the job.”

Keith could feel himself getting angry. What was Pete trying to say anyway? He could take his uncle’s job and...Wait! Keith thought to himself. Pete and I used to hang out when neither one of us was very serious about work. How does he know I have changed? Keith took another deep breath and explained the situation to Peter.

“I’ve been working pretty hard at CUES for the past year. I know that I want to work in construction, so if you would talk to your uncle, I’d really appreciate it.”

“Okay, I will,” said Pete.

A few days later Keith got a call from Pete.

“Uncle Louie wants to see you tomorrow morning at eight — that’s sharp,” he said.

Keith got the address and figured out how to get there by bus. He arrived at 7:40.

Keith liked Louie right away. The interview went well, and it was arranged that Keith would start on Monday morning.

Now as Keith lay in bed, he could hardly believe his good fortune. He had always liked Pete, but who knew that their friendship would make this kind of difference in his life? I'd better not screw up, Keith murmured to himself. He was getting sleepy.

Job Search Strategy



When Keith asked Pete about a job at Straight Path Construction, he was tapping into the **Hidden Job Market**. What's that? There are many jobs available that never get advertised, so these jobs are "hidden." How do you learn about these jobs? Through networking with friends and associates. Keep your ears and eyes open. Let people know about the kind of work you are looking for. Like Pete's Uncle Louie, most people who do the hiring would prefer to hire someone who comes recommended.

Try this:

List three people you could network with.

Find an online article on the **Hidden Job Market**.

List three things you could be doing to tap into the market.

Keith arrived on the job site early on Monday morning. Many of the experienced workers were already there. Pete was taking orders for coffee.

"Hey, Keith! Double double?"

"Yeah, thanks!" He handed Pete some change.

Keith was supposed to have a short orientation session with his supervisor, but the weather had been bad all the week before, and Straight Path Construction was behind on this job. His supervisor, Mario, handed him a shovel and laughed.

"Dig now, orientation later," he said.

By the end of Keith's first day, his construction boots no longer looked new and his hat was dirty from the mixture of rain and mud. At home Keith popped open his lunch pail and took out some papers the supervisor had handed to him when he clocked out.

"Have these back to me tomorrow," Mario had said.

Reading the New Worker Orientation

Many places of employment have policies and procedures that the worker is responsible for knowing. At Straight Path Construction, new employees are given a **New Worker Orientation** (see next page), which explains a number of important policies.



What is a policy?

Workplace Know-How



A policy is a guideline for carrying out work. Policies are the operating standards that workplace management has put into place. They can include regulations about employee behaviour and expectations. Policies can also include the obligations of the employer.



What is the difference between a policy and a procedure?

A policy provides the framework and the goal of the workplace. Procedures provide specific information on how that goal will be reached.

When Keith looked at his **New Worker Orientation**, he tried to skim through it quickly. He read the headings, but they did not make sense to him. I don't understand this at all, he thought. Keith thought back to the different kinds of reading that he had learned at CUES. His favourite had definitely been "skim and scan." Keith liked to look through a document quickly. When he read the paper, he read headings and the first few paragraphs. He liked it when information was in point form so that he did not have to read lots of text.

STRAIGHT PATH CONSTRUCTION

NEW WORKER ORIENTATION

To be reviewed upon hire orientation

NAME OF EMPLOYEE	REVIEW OF POLICY and PROGRAM	NEW WORKER ORIENTATION	WHMIS	FALL ARREST

COMMENTS/ADDITIONAL TRAINING

MISCELLANEOUS POLICIES

Timesheets

- Are to be clearly and accurately filled out (sample attached) and handed in to the office by Monday at 5:00 pm. Failure in doing so could result in delay of your pay cheque being released. Job numbers are available through your supervisor or by contacting the office directly. If you are absent for any reason (e.g., sickness or holiday) or require any “special” payment etc., document it in your timesheet prior to submission so both the employee and employer have recorded documents.
- Your signature is required as well as your supervisor’s signature for payment/process.

Paperwork/Purchases

- Each purchase is to have a P.O. number and a readable signature.
- When you are to make a purchase, call the office from the supplier’s location for proper P.O. number.
- Bring all packing slips for purchases either to our Supervisor or directly into the office.

Garnishment of Wages

- If Straight Path Construction has to garnishee an employee’s wage (as ordered by the Ministry or Government), a charge of \$40.00 per occurrence will be deducted from your pay accordingly.

STRAIGHT PATH CONSTRUCTION

NEW WORKER ORIENTATION

To be reviewed upon hire orientation

MISCELLANEOUS POLICIES (cont/d)

Absentee Reporting

- Any employee not reporting to work must give proper notification to the office prior to 8:00 am of that day.
- Contact the office at (613) 491-7023. If there is no one there to answer your call, leave a message on the answering machine available 24hrs/day.
- Contact the office each and every day employee is absent. Neglecting to do so will be documented against the employee.
- 2 or more consecutive days absent will require a doctor's note upon return to work.
- Absence from work without proper notification will be dealt with as follows:
 - 1 day off without proper notification equals 2 days off without pay.
 - 2 days off without proper notification equals 4 days off without pay.
 - 2 or more days off without notification may lead to termination (at the discretion of the C.E.O.).

W.S.I.B.

- If an accident occurs, the employee must notify the Supervisor by the end of his or her shift that same day.
- Every effort will be made to return our employee back to work as soon as possible after an incident. Employee must keep in contact with the office each and every day after an incident occurs (and the day of the incident).
- Modified work will be made available if the employee is qualified, available and fit to do such work.

W.H.M.I.S.

- Any material safety data sheets are to be kept on the job site with a copy submitted to the office.

I, the undersigned, acknowledge that I am familiar with Straight Path Construction's Health and Safety Policy and Program. I also understand that all safety issues are addressed in the policy and program manual, a copy of which has been distributed to me. I have completed the new worker orientation and I agree to adhere to this policy and program and work in compliance with the Occupational Health & Safety Act for Construction projects.

Employee Name/Signature

Straight Path Construction Authorized Name/Signature

Keith looked at the **New Worker Orientation** again. I guess I am going to have to read this more carefully, he thought.

Keith read the headings. He decided that there were three important sections for him to read and three that were less important.



JOB TASK ONE: Reading New Worker Orientation

1 Which three sections do you think are most important for Keith? Why have you chosen these three?

2 Which sections are less important for Keith? Why do you think so?

3 Read the **New Worker Orientation** and answer the following questions:

a) When should the timesheets be handed in to the office? What happens if they are not submitted on time?

b) Why is it important to record your absences on the timesheet?

c) Who needs to sign your timesheet so that you get paid?

d) If you work for Straight Path Construction and are too sick to go to work, what should you do?

e) What should you do if you have the flu for three days?

f) If you fall and sprain your ankle on the job at Straight Path Construction, what should you do?

4 Is Keith ready to sign the **New Worker Orientation**? Why or why not?

After reading through the **New Worker Orientation**, Keith realized that he needed to read the **Health and Safety Policy Program** before signing anything. He could see that he wouldn't be playing any pool with his friends tonight; the Health and Safety document was over ten pages long! He would need to take his time if he wanted to understand what he was signing.

Keith is right: reading a complicated and lengthy document needs more time. He is familiar with skimming and scanning, but there are other strategies he could use. Take a look at the strategies on the next page and try using them as you read the health and safety document for Job Task Two.

Before starting Job Task Two, look at the following reading strategies.

Reading Strategies



- Read the Table of Contents, and pay close attention to the section titles. Try to think about what kind of information is in each section.
- Look over the **bolded** headings and sub-headings.
- Look over any charts, graphics and diagrams; they are there to illustrate and make information clear.
- Notice any reading aids such as *italics*, **boldface** or **colour**; they are being used to highlight something important.
- Break up large documents into smaller sections; reading a small section at a time is a more manageable task than reading the whole document.
- Decide which sections are most important — read those first, highlighting key pieces of information.

Once you start reading, try these strategies:

- Highlight sections that you need to remember
- Star sections which are most important for you
- Try reading aloud if it makes the information clearer
- If it helps you to remember and understand, make notes in the margins or on a separate page



JOB TASK TWO: Reading Health and Safety Policy Program

NOTE: Document starts on page 56.

Once Keith took a closer look at the document, he realized that he didn't have to remember everything in it. In Section One, only one small part was meant for him.

- 1 Which part does Keith need to read in Section One? Why doesn't he need to read the other parts?

- 2 What does Keith need to know in Section Two?

- 3 What should you do if you are injured at work?

4 What procedures should you follow if a serious injury occurs?

5 What disciplinary action will be taken if you violate health and safety procedures?

6 How often are workers expected to attend safety meetings?

7 What will Keith learn at his New Workers Orientation?

8 What types of training will Keith need to have so he can work safely on the job site?

HEALTH & SAFETY POLICY STATEMENT

The Management of Straight Path Construction recognizes and accepts our responsibility for the health and safety of our workers and will conform to the requirements set out in the Occupational Health & Safety Act and Construction Regulations. Our goal is to have zero lost time injuries.

Employees of Straight Path Construction, our sub-contractors and their employees have the right to a safe and healthy work environment and therefore must protect his or her own health and safety by following the laws and safe work practices and procedures. Appropriate action by Management will be taken against any employee who engages in an unsafe practice or who fails to comply with established safe work practices and procedures.

It is in the best interest of all parties to consider health and safety in every activity. There is no task so urgent or a deadline so important that time cannot be taken to execute a project safely.

Straight Path Construction considers that safety/loss control, quality and productivity are natural results of efficient Teamwork.

Authorized Representative
Straight Path Construction

Employee's Signature

Dated

August 2009

STRAIGHT PATH CONSTRUCTION

HEALTH AND SAFETY POLICY AND PROGRAM

Health & Safety Policy Statement

TABLE OF CONTENTS

Section 1	Major Parties' Responsibilities
Section 2	Environmental Policy
Section 3	Enforcement Policy
Section 4	Accident Reporting / First Aid / Early Return to Work and Modified Work / Contact Phone Numbers
Section 5	Health & Safety Practices
Section 6	Safety Meetings
Section 7	New Worker Orientation and Site- Specific Orientation
Section 8	Procedures

SECTION ONE

Major Parties' Responsibilities

President, CEO, Management

- Ensure that all policies and procedures are adhered to
- Projects are progressing / completed on time and on budget
- Ensure that all employees under their control work in a safe and proper manner
- Ensure that safety rules are enforced

Supervisor

- Advise a worker of the existence of any potential or actual danger to the health and safety of the worker of which you are aware in compliance with the Acts and Regulations.

- Take every reasonable precaution in the circumstance for the protection of the worker (inspect tools, work area, etc.).

- Ensure a worker uses or wears the equipment, protective devices or clothing that is required to be worn or used.

- Plan job and ensure materials/equipment/tools, etc., are on project site as needed.

- Accident investigation.

- Profitable job upon completion.

Workers/Employees

- Work safely in accordance with Health and Safety Policy and Program.

- Report hazards or unsafe conditions to their supervisor after taking appropriate immediate action.
- Report all accidents or injuries (and near misses) to the Supervisor immediately.
- Clean-up of work area daily.
- Wear safety equipment, personal protective devices, clothing and footwear required – a minimum of CSA approved hard hat and footwear.
- Only perform duties for which you are qualified, trained and authorized.
- Attend safety meetings/tool box talks as required and requested.

Sub-Contractors

- Maintain a health and safety program as required under the Act.
- Report accidents or any hazards immediately to Contractor.
- Coordinate all work activities through Site Supervisor.
- Conduct clean-up of work areas at least daily.

Health and Safety Representative

- Only required when there are between 6-19 workers regularly employed in the workplace. If less, the supervisor will be responsible.
- Report hazards and make written recommendations to Supervisor.
- Attend regular health and safety meetings on site.
- Help implement health and safety program.
- Assist in accident investigations, help fill in paperwork, file and submit paper work to W.S.I.B. accordingly.

SECTION TWO

Environmental Policy

At Straight Path Construction, we care about the environment. We accept the responsibility entrusted to us to conduct our operations and offer our services in an environmentally responsible manner.

We are committed to excellence in implementing standards of care that not only comply with legislated requirements but also respond to the environmental expectations of our community, customer and the public. Management will demonstrate that environmental responsibility is critical and that employees at all levels will be made aware of the potential impacts associated with their activities and trained accordingly.

Straight Path Construction will be prepared in the event of an accidental release of contaminants to respond promptly in a manner that is protective of the health and safety of its employees and the public and mitigates the impact on the environment.

SECTION THREE

Enforcement Policy

The Company will not condone any breach of our requirements set out in our Health & Safety Program. The company has implemented the following disciplinary actions for violations.

1. Verbal Warning (First Warning)

In the opinion of the Supervisor, is a violation that has occurred which will directly endanger the health & well-being of those on the job site. Supervisor will discuss violation and document it accordingly.

2. Yellow Warning (Second Warning)

Is a violation that has occurred which will directly endanger the health and well-being of those on the job site. Supervisor will review violation and determine appropriate suspension (usually 2 days without pay) and/or action and document it accordingly.

3. Red Warning (Third/Final Warning)

In the opinion of the Supervisor, the violation is life threatening to those on the job site. Management will

16

CLASS A



Compressed Gas

CLASS B



Flammable and Combustible Material

CLASS C



Oxidizing Material

CLASS D



2. Materials Causing Other Toxic Effects



3. Biohazardous Infectious Materials



1. Materials Causing Immediate and Serious Toxic Effects

CLASS E



Corrosive Material

CLASS F



Dangerously Reactive Material

WHMIS Classes and Hazard Symbols

decide upon termination and/or action (depending on severity).

SECTION FOUR

Accident Reporting/First Aid/Early Return to Work and Modified Work/Contact Phone Numbers

- All injuries, no matter how slight, must be reported to your immediate supervisor before leaving at the end of the shift.
- Every effort will be made to return our injured employee back to work. Employee must contact the office each day to review his/her availability for modified work or regular work, if that can be achieved.
- Once the disability allows the worker to return to his/her regular duties or modified duties, he/she shall do so.
- If serious injury occurs, follow this procedure:
 - Call 911
 - Do not attempt to move an injured person unless he/she is caught or trapped.
 - Loosen all tight clothing around the neck, chest and waist.
 - If breathing is absent, commence artificial respiration.
 - If bleeding is present, apply pressure.
 - Do not give water (to prevent choking).
- Contact Phone Numbers

- Emergency 911
 - Straight Path Construction 613-491-7023
Emergency Procedures

1. **Take Command:** Assign duties to specific personnel.
2. **Provide Protection:** Protect the accident scene from continuing or further hazards.
3. **Give First Aid** to the injured as soon as possible.
4. **Call an Ambulance:** Call an ambulance and any other emergency services required. Dialing 911 puts you in touch with all emergency services.
5. **Guide the Ambulance:** Meet and direct the ambulance to the accident scene.
6. **Get Name of Hospital:** For follow-up, find out where the injured is being taken.
7. **Advise Management:** Inform senior management. They can then contact relatives, notify authorities, and start procedures for reporting and investigating the accident.
8. **Isolate the Accident Scene:** Barricade, rope off or post a guard at the scene to make sure that nothing is moved or changed until authorities have completed their investigation.

SECTION FIVE

Health and Safety Practices

In addition to the Acts and Regs, we stress the following:

- Workers must read and become familiar with the Company's health and safety program. Ask your Supervisor to clarify anything you do not understand.
- Any person(s) entering work area must wear a minimum CSA approved hard hat and footwear.
- No employee shall work in manner that will endanger another person. Think before you act.
- The use of intoxicating substances will not be permitted at any time at any job site. Smoke only in permitted areas. Testing for drugs may be required before entering certain job sites.

To recognize individual employees for their continued commitment to Health & Safety, Straight Path Construction can offer bonuses and incentives to show our appreciation to their dedication.

SECTION SIX

Safety Meetings

1. Tool box talks (weekly) attended by Supervisor(s) and Workers.
2. Trades Committee Meeting (every 2 weeks) attended by selected Trade Representatives.
3. Safety Orientation Meeting (at time of hiring).

HAND SIGNALS

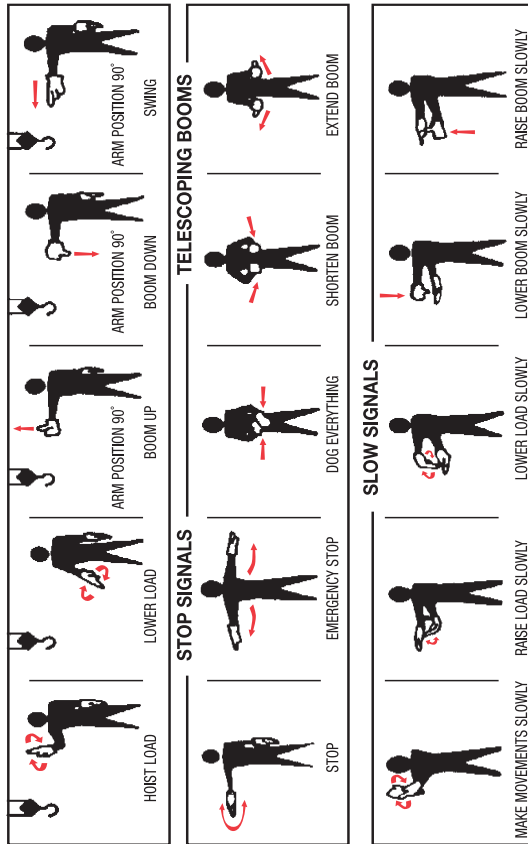

SECTION SEVEN

New Workers Orientation

- Explanation of project and of duties.
- Review and issue copy of company policy and program.
- Reporting of accidents, review W.S.I.B. forms, available contact numbers.
- Review submission of timesheets, paperwork (invoices, packing slips, etc.), absentee reporting and miscellaneous items noted Company Manual.
- WHMIS training.
- Fall Protection training and record of training.

Site-Specific Orientation

- Location of first aid kit, fire extinguisher, telephone numbers and emergency numbers.
- Requirements for personal protective equipment (minimum CSA footwear and hard hat).
- Location and details of specific project hazards.
- Location of parking, lunch area, toilets and smoking area.
- Supervisor name and health and safety representative.

- Leveling legs and locking pins to be used on all scaffolding.
- Check scaffolding thoroughly and carefully before erecting on project site.
- Conform to respective Act and Regulations.



SECTION EIGHT

Procedures

Fall Protection

- Proper in-house training of fall arrest to be conducted.
- Procedures will be discussed while being trained.
- Conform to site specific fall protection requirements.
- Conform to respective Act and Regs.

Scaffolds and Ladders

- No scaffolds are to be erected without Supervisor present and only a competent worker shall do the erecting.
- Overhead work should be planned carefully with the Supervisor and all employees involved and arrange all necessary safety precautions including fall arrest system.
- Base of ladders should be placed approximately 25% of its length away from the base of the structure to be mounted.
- Make sure ladder is long enough for the job and that there are no defects.
- Never overreach when on a ladder. One arm's length in either direction is maximum or move ladder.
- Nothing should be carried while climbing or descending a ladder and always face the ladder.

Tools and Equipment

- Keep tools, equipment, company owned or rented, in good working order and in correct place when both in use and not in use.

- Never use tools or equipment with defective or worn parts. Have a competent person show you the proper way to use specific tools and never operate equipment that you are not qualified to use.
- Do not carry sharp edged tools in pockets.
- Always use a tool for its proper intended use and never leave it unattended.
- Label gas cans or other material holding cans with proper identification tag listing date filled and description of fuel/material in can.
- Log company owned tools and equipment in log book before leaving shop and return item in proper working order and in proper location.

Formwork, Shoring, Etc.

- Formwork shall be constructed, supported and braced so they are capable of withstanding all loads likely to be applied to them.
- Formwork shall be installed under the supervision of a competent person.
- Some main hazards in this operation are:
 - falls (lack of guardrails, fall arrest system), struck against/struck by, collapses (come loose, slip out of place), dust and concrete (blowing dust and flying concrete particles) and access equipment (ladders, scaffolds).
- Conform to respective Act and Regulations.

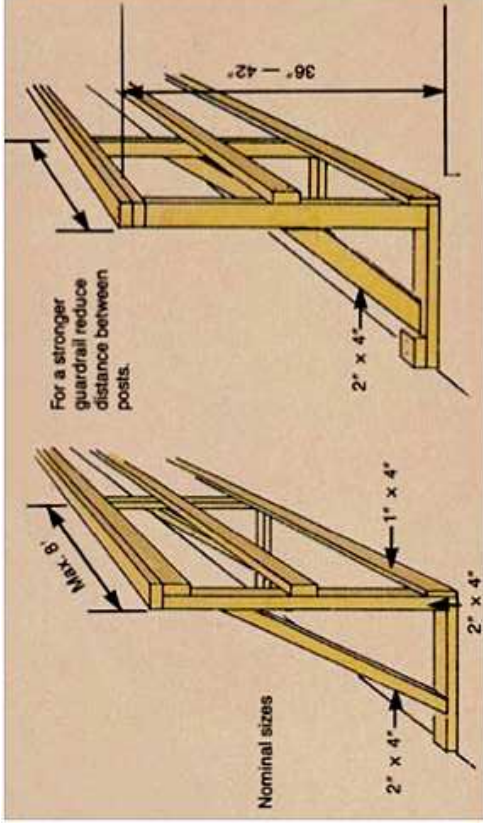

Proper Guardrails with Typical Dimensions

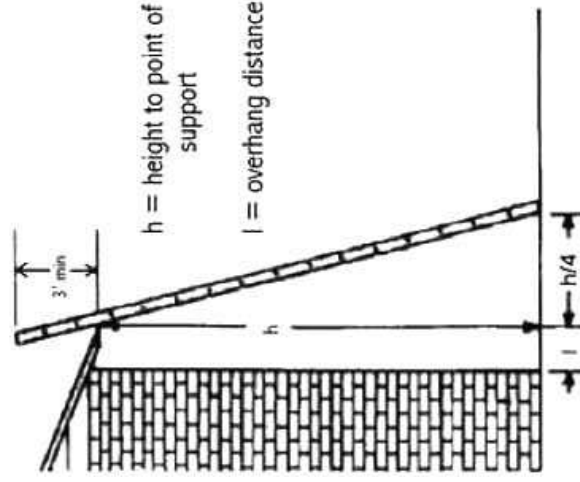

Proper Ladder Angle

- Only the person tapping and locking the equipment shall remove the same.
- The Supervisor may remove tag and lock only if the worker who applied the lock-out is absent.



Heavy Equipment

- All vehicles, machinery and equipment must be maintained in a condition that does not endanger a worker.
 - Copies of the manufacturer's operating manual shall be kept available.
 - Must be inspected by a competent person before its first use on a project and at least once a year professionally.
- Only qualified and authorized workers may operate any vehicles, machinery and equipment on the project.

Lock Out

- Determine equipment/location to be isolated.
- Locate manual switch and disconnect switch for equipment on panel.
- Turn manual switch to "Off" position and turn disconnect switch to "Open" position.
- Fasten "lock-out tag and lock" to "opened" disconnect switch for isolated equipment.
- If more than 1 person is working on equipment, then each person(s) must have his/her own lock-out tag and lock.



OVERTIME ACTIVITY: Review Policies and Procedures

If you are studying at an adult upgrading centre, they will have a policy manual. Ask to see it! Follow the steps you learned in Job Task Two to give you an overview of the policy manual contents.

Performance Review

In this chapter you have worked on essential reading skills for work. How do you think you did? Use the chart below to reflect on your improved ability to use reading skills for work.

Essential Skill	Exceeds Expectations	Meets Expectations	Needs Additional Training	LBS	ES
Reading					
I can skim and scan for information.				2	1
I can read simple texts for several pieces of information.				2	2
I can interpret information from a single text.				2/3	3
I am able to distinguish between relevant and irrelevant information.				3	3
Other Essential Skills					
Document Use					
I can use text organizers (table of contents, titles, headings, etc.) to locate information.					1

CHAPTER 3

Erica Reads

Do you have the skills necessary to read longer, complicated documents? Do you have the studying and test-taking skills necessary to write multiple choice tests?

Employability Skills	I have this skill.	I am not sure.	I need to work on this skill.
I can read a Table of Contents to locate information.			
I can read a Glossary to get word definitions.			
I can break up a longer document into smaller, manageable sections.			
I can read and organize a longer document.			
I am able to use study and test-taking strategies.			

Part One



Job Shadowing: Reading Longer Documents/Preparing for a Test

Erica arrived at work to find Sam and Edna in deep and excited conversation. They had spread out a large colourful pamphlet on the counter. Erica caught a glimpse of very blue water and palm trees.

“Is someone going on vacation?” she asked.

“We are!” said Edna. “We’ll be celebrating our 20th anniversary next month, and my sister and brother-in-law will be celebrating their 25th. We’ve decided that we’re going to Cuba on a holiday together.”

“Wow,” said Erica as she struggled out of her coat and heavy boots. “What are you going to do about the bakery while you’re away?”

“We’re still working out some of the details on that,” said Edna. “Sam’s uncle is a retired baker. He has offered to come in and do the baking. You, Ryan and Jackie will all be working full-time.”

“That doesn’t sound too bad,” said Erica, who already works full-time.

Edna continued, “One of the most important things to get done is to get you and Jackie your safe food handling certificates. The law requires that at least one staff member on shift has the certification.”

“Oh. How do I do that?”

“I’m not sure,” said Edna. “It’s been a while since I did mine. You will need to give the health department a call today and find out.”

Erica nodded. If she had been told that she needed extra certification when she had first started working at Dough Dude Bakery, she would have panicked. But since working, she had gained lots of confidence in her ability to learn new skills.

Erica had also improved her speaking skills. Now she went into Dough Dude Bakery’s tiny office and opened the phone book. She quickly found the number for the Public Health Unit.

Workplace Know-How



Employers will often want their employees to upgrade their skills when they have been on the job for a while. You may have to retake the WHMIS test on a regular basis or take a test on the care and use of a new piece of equipment. Knowing how to prepare for and take a test will make it easier to progress on the job. Employers value an employee who is able to learn new skills and demonstrate them.

The person she spoke to at the health department had been very helpful. She had recommended that Erica visit their website and download their recent copy of **The Food Handler’s Guide**. Erica went to the website and clicked on the guide. She was surprised to see that it was over 70 pages long! Erica wondered if she was ever going to get through all of this information and pass the test.

Are you like Erica? Do you find long documents difficult to get through? There are several strategies you can use to make long documents easier to manage. Some of the strategies Keith used in the previous chapter will work well with longer documents as well. Documents you need to know in order to pass a test require extra effort and organization. The following tips will make reading long complicated documents easier.

Before starting to read



- Look at the Table of Contents
- Look at titles, headings and sub-headings
- Look at captions under pictures
- Look at bolded sections
- Look at introductory and concluding paragraphs
- Read the chapter summary first
- Ask yourself or jot down what you already know
- Decide on which sections will need extra review. These are usually the sections you have no prior knowledge about.

Erica realized she already knew some things about the safe handling of food. Sam and Edna had both stressed the importance of proper hand washing and the use of sterile gloves when handling food. The bakery was also regularly cleaned and sterilized. She decided to review the **Table of Contents** first to see what areas she would need to spend extra time on.



JOB TASK ONE: Reading a Table of Contents

Look at the Table of Contents on the next page. Answer the questions that follow it.

Table of Contents

Public Health Legislation and the Local Health Department	3
The Health Protection and Promotion Act (HPPA)	4
Food Premises Regulation	5
By-laws	6
Role of the Local Health Department	7
Review Questions	8
Understanding Foodborne Illness (Food Poisoning)	9
Costs of Foodborne Illness (Food Poisoning)	10
Commonly Used Words	11
Understanding Micro-organisms	12
How Bacteria Grow	13
What Pathogenic Bacteria Need to Grow	14
What is Foodborne Illness (Food Poisoning)	16
Types of Foodborne Illness	17
Allergies and the Role of the Foodservice Industry	26
What to Do if Someone Reports a Possible Foodborne Illness	27
Review Questions	29
Safe Food Handling	30
Temperature Control	31
The Danger Zone	32
Cook Food Thoroughly	34
Defrost Food Safely	36
Cross-contamination	37
Handwashing	39
Handwashing Basins	40
Glove Use	41
Personal Hygiene	42
Hazard Analysis Critical Control Point System (HACCP)	43
6 Steps to a HACCP System	44
Review Questions	48
Food Premises Sanitation	49
Cleaning and Sanitizing	50
Machine Utensil and Dishwashing	51
Machine Dishwashing	52
Manual Utensil and Dishwashing	53
Manual Pot and Oversized Utensil Washing	54
Dishwashing by Hand	55
Housekeeping	57
Sanitary Facilities	59
Pest Control	60
Review Questions	62
Appendix	63

1 Which chapter (chapters are bolded) is likely to be the easiest for Erica? Why?

2 Which chapters will be more challenging? Why?

3 Use a highlighter, or underline sections Erica needs to spend extra time studying. Put checkmarks beside the sections where she already has some knowledge.

4 Which chapter would have information on the responsibilities of the Public Health Unit?

5 Which chapter has information on how to keep a clean work environment?

Once Erica looked over the **Table of Contents**, she was a little more relaxed. “I already know some of this; I am sure I can learn the rest. The section on **foodborne illness** is likely to be the hardest, so I think I should start there,” she said to herself.

Erica had noticed in the **Table of Contents** that each chapter had some review questions at the end. She decided that might be a good place to start.



Why is it a good idea to read the review questions first?

Erica soon realized that highlighting and underlining would not be enough to help her remember everything for the test. She needed some paper and maybe some flashcards.

Test-taking strategies

- Read chapter questions and summaries first and look for that information while you are reading
- Break the chapters into smaller parts, using the headings
- Highlight main ideas while reading
- Use flashcards for definitions
- Don't be afraid to write in the margins
- Organize complicated information into a simpler, easier to read format



JOB TASK TWO: Reading Longer Documents

- 1 A part of the chapter on food borne illness is inserted on pages 73 to 76. Read through it carefully. Highlight any words you do not understand. Don't stop reading until you get to the end. When reading longer, complicated documents, it is useful to write difficult words on flashcards. You can look them up later and definitions can be written on the back of the cards. Flashcards make good study tools.
- 2 Sections containing similar information can be confusing and difficult to remember. This same information organized into a chart can become a terrific study tool.

Using the chart provided, read and organize the information on foodborne illnesses. Be sure not to rewrite the document. Just use key words and phrases. The first entry is started for you.

Highlighting key information as you read and organizing that same information into a chart helps you remember complex documents. Several pages of text are now on one page.

Microbiological Foodborne Illnesses					
Bacterial Infection					
Infection	Source	Food	The Disease	Prevention	
Salmonella	Intestinal tract, feces- humans, animals	Meat, milk, eggs			
Bacterial Intoxication					

Types of Foodborne Illness

Microbiological

The most commonly reported micro-organisms that cause food poisonings are bacteria.

Most bacterial food poisonings last for a few days and clear up on their own. Antibiotics can be prescribed and are effective against bacteria. They will help your immune system fight and eventually destroy the bacteria.

There are two types of bacterial foodborne illness:

A. Bacterial Infection

- ▶ Food poisoning infection can occur when the food eaten is contaminated with living pathogenic bacteria

You must eat the living bacteria to become ill. Food can contain a large or small amount of bacteria to cause illness, depending on the type of bacteria. The amount and type of bacteria will determine the time for symptoms to appear.

- ▶ Bacteria will multiply in the digestive tract and most often cause diarrhea, stomach cramps and fever

The bacteria will pass through your stomach and down into your lower intestine. The bacteria will embed themselves in the wall of the intestine and begin to multiply. When there are enough bacteria, diarrhea will result, sometimes bloody.

- ▶ Examples of infectious bacteria are **Salmonella**, **Campylobacter**, **E. coli** and **Shigella**

These are the most common; however, there are many other types as well. There are over 2,000 types of **Salmonella** alone.

Infection: SALMONELLA	
Source	Intestinal tract and feces of humans and animals, in particular, poultry and beef
Foods	Meat and meat products such as roast beef, meat pies, sausage, ham, poultry, poultry products, milk and eggs (especially cracked eggs)
The Disease	Symptoms occur 6 to 72 hours after eating, usually 12 to 36 hours (diarrhea, stomach cramps and vomiting are the usual symptoms)
Prevention	Proper handling, processing, storage and preparation of food

Infection: E.COLI 0157:H7	
<p>E.COLI 0157:H7 bacteria are the most harmful strain of E.coli bacteria known The very young and very old are the most likely to be affected by major complications such as kidney failure and even death.</p>	
Source	Intestinal tract and feces of humans and animals, in particular, cattle.
Foods	Raw meats such as ground beef, poultry, pork, unpasteurized milk, contaminated water
The Disease	<ul style="list-style-type: none"> • Symptoms occur 3 to 10 days after eating or drinking, usually 3 to 4 days (bloody or watery diarrhea, abdominal cramps) • 0157:H7 infections may develop hemolytic uremic syndrome, with possible permanent kidney damage, even death
Prevention	<ul style="list-style-type: none"> • Cooking food thoroughly • Proper handwashing using soap and water • Drinking only pasteurized milk • Drinking water from a safe water supply

B. Bacterial Intoxication

- ▶ Food poisoning intoxication can occur when the food eaten is contaminated with toxins (poison) or toxin producing bacteria

The bacteria multiply in the food and a by-product of this multiplication is toxin. The toxin is the poison that causes the illness. The toxin producing bacteria can multiply in the food or in the body and not all toxins are destroyed by cooking.

- ▶ Vomiting is the most common symptom in intoxications

As you eat the toxin and it enters into your system, your body realizes that this is not good for it and vomits this poison out.

- ▶ Examples of bacteria which produce toxins are **Staphylococcus aureus**, **Bacillus cereus** and **Clostridium botulinum**

Again, there are many types of bacteria that produce toxin and will cause an intoxication. **Staphylococcus aureus** is usually found on the skin, in the nose and throat area. **Bacillus cereus** is usually found in cooked rice.

Intoxication: STAPHYLOCOCCUS AUREUS	
Source	Nose, throat, hair, skin, hands and feces of humans and animals
Foods	Ham, beef, pork, poultry, potato salad, custard, cream sauces, puddings and fermented dairy products
The Disease	Symptoms occur 30 minutes to 8 hours after eating, usually 2 to 4 hours (vomiting, stomach cramps and diarrhea are the usual symptoms)
Prevention	<ul style="list-style-type: none"> • Cook food thoroughly and do not allow toxins to form • Practice good personal hygiene, including properly washing hands often

Intoxication: BACILLUS CEREUS	
Bacillus cereus bacteria presents two types of illness — diarrhea and vomiting	
Source	Found everywhere in the environment, especially in soil
Foods	<ul style="list-style-type: none"> • Diarrhea: soups, custards, meat, poultry • Vomiting: Chinese-style foods, rice
The Disease	Symptoms are usually mild; nausea, cramps, vomiting (usually within 30 to 60 minutes) and diarrhea (usually 3 to 5 hours)
Prevention:	<ul style="list-style-type: none"> • Cook food thoroughly and do not allow toxins to form • Keep hot food hot at 60°C or more (140°F or more) • Keep cold food cold at 4°C or less (40°F or less)

Erica had all the information on foodborne illnesses organized. She also had a stack of vocabulary words. She needed to get the definitions for these.



JOB TASK THREE: Reading a Glossary

A glossary is a list of technical or difficult words with their definitions. They are usually found at the back of a book. Take a look at the glossary that starts on the next page. Does it contain any of the words you highlighted before? See if you can locate some of the words.



What do you notice about how the words are organized?
Why is it important to organize a glossary in this way?

Glossary

Allergy	a condition of heightened sensitivity to a substance such as food.
Anaphylaxis	a severe, life threatening, generalized allergic reaction.
By-laws	laws created by Municipal or Regional governments to deal with important issues that fall under their jurisdiction and are not dealt with at the provincial or federal level.
Chlorine	a greenish, yellow, poisonous gaseous element used as a disinfectant or sanitizer. Usually used in a liquid form for disinfecting food contact surfaces and the sanitizing sink in 2 and 3 sink dishwashing systems.
Clean	to remove oil, grease, dirt and debris, using soap and water.
Contamination	introduction of micro-organisms or disease agents into food.
Critical Control Points (CCP)	in a Hazard Analysis Critical Control Point System, the point in a recipe where a hazard exists and a control measure is used to eliminate, prevent or minimize that hazard.
Cross-contamination	the introduction of micro-organisms or disease agents from raw food into safe or ready to eat food, making the ready to eat food unsafe. This can happen in 3 ways. Raw food or its juices come in contact with cooked or ready to eat food. Contaminated hands touching food. Using the same equipment or utensils to handle raw and cooked food.
Cutlery	multi-service articles such as knives, forks and spoons.
Danger Zone	the temperature range 4°C to 60°C, in which micro-organisms grow and multiply extremely well.
Diarrhea	a disorder of the intestine marked by abnormally frequent and fluid evacuation of the bowels.
Disease	a condition of ill health.
Disinfection Solution	a mixture of a disinfection chemical and water in a certain ratio that will be used to disinfect or sanitize food contact surfaces, equipment and multi-service articles.
Enterotoxin	a toxin with specific action on the intestinal lining.

Foodborne Illness (Food Poisoning)	a disease caused by eating or drinking contaminated food and/or water.
HACCP (Hazard Analysis Critical Control Points)	a system used throughout the food industry to enhance food safety. The system looks at hazardous food, identifies the greatest risk factors, makes the necessary changes to reduce or eliminate the risk and monitors the overall food handling.
Handwashing	the physical action of removing dirt and micro-organisms from the hands, using soap and water, scrubbing for at least 15 seconds, rinsing and drying with paper towels.
Hazardous Food	food that is able to support the growth of pathogenic micro-organisms or the production of toxins.
Host	any living organism (often human) in which micro-organisms grow and multiply or toxins exert their effect.
Infection	a condition in which micro-organisms establish themselves and multiply in the host's body.
Intoxication	an adverse reaction by the body to a foreign (toxic) substance, whether the substance was produced within or outside the body.
Iodine	a chemical used as a disinfectant or sanitizer. Very expensive and can stain multi-service articles.
Micro-organisms	invisible living single cells.
Multi-service Articles	cutlery (forks, knives, spoons) and dishes (plates, bowls, cups) that must be cleaned and sanitized after each use.
Parasites	organisms that cause illness by living and feeding off a host organism. Do not necessarily cause disease.
Pathogen	harmful micro-organisms that can cause disease in humans.
Pathogenic Bacteria	colourless and odourless bacteria that cause disease in humans.
PH	is the measure of the level of acidity or alkalinity of a solution and ranges from 0 to 14. Pathogenic bacteria need a neutral environment to survive. High or low pH will not kill pathogenic bacteria but will not allow them to grow.

Preparation (of food)	the final stage(s) of readying a food to be eaten, whether commercially or in the home; usually done in a kitchen.
Processing (of food)	the treatment of food, usually on a commercial scale, to increase its usefulness, stability or acceptability.
Production (of food)	the growing, usually under human supervision, of the basic animal or vegetable material of a food.
Protein	complex organic nitrogenous compounds that are used as a food source by living organisms.
Provincial Legislation	acts and regulations passed by the provincial government. The legislation must be followed throughout the province.
Quaternary Ammonium	a chemical used as a disinfectant or sanitizer. Commonly used in the sanitizing rinse cycle of mechanical dishwashers.
Retailing (of food)	the display and sale of food in a store for later consumption off the premises.
Sanitize	to destroy unwanted contaminants such as bacteria and viruses, using a chemical substance to kill 999 out of 1000 pathogenic micro-organisms.
Service (of food)	the final preparation and sale or giving of food for consumption on the premises (in a restaurant or cafeteria) or elsewhere (a take-out); can also include outdoor group feeding at picnics.
Source (of a contaminant)	where micro-organisms originate (human or animal intestines).
Spores	a resistant body formed by certain micro-organisms when exposed to unfriendly environments.
Sterilize	to kill all micro-organisms.
Utensils	multi-service articles used in preparation, cooking and serving such as ladles, tongs and spatulas.
Viruses	micro-organisms that multiply inside living cells and cause illness.

Wash In Place

a system to clean, rinse and sanitize large equipment that cannot be cleaned in a dishwasher or sink. The equipment must be washed with soap and water and rinsed with clean water. The sanitizing rinse can consist of hot water or steam sprayed on the treated surface to a minimum temperature of 82°C or a chemical solution sprayed on the treated surface at double the strength used for manual dishwashing.

Part Two

Erica studied the material for the Food Handler's Course for several evenings. She read through the most difficult material first; she had several charts made up with what she hoped was the most important information. She also had a stack of flashcards with definitions. A friend was coming over this evening to quiz her on what she had studied. She hoped to be ready to write the test on Monday. She was glad it was a multiple choice test. Those are easy, she thought.



Is Erica right that multiple choice tests are easy? Why or why not?

Erica will need to bring her reading skills with her when she writes the Food Handler's test. She will be tested on her knowledge and her reading ability. If she wants to do well, she will need to recognize and apply the information she has learned and she will need to know exactly what is being asked.

There are three parts to a multiple choice question: the question, the correct answer and the incorrect answers. Another word for the incorrect answers is distracters.



Why do you think they are called distracters?

Distracters may include common mistakes or misunderstandings, or be a true statement that is not related to the question. They may include similar words or numbers intended to confuse the test taker.

Erica will want to use the following test-taking strategies:

- Relax, breathe and let your memory kick in
- Look over the test to see how it is organized
- Keep an eye on the time; don't spend too much time on any one question
- Leave time at the end to look over your answers
- Read the whole question and look for keywords and phrases
- Read all the answer choices even if you think you know the right answer
- Eliminate any answers you know are wrong
- Read the question and answer together to see if they flow smoothly
- If you do not understand one question, go on to the next question
- Guess and move on if you do not know the answer
- Put a mark beside a question you want to go back to
- Go with your first choice unless you have a good reason to change it
- Answer every question





Have you ever written a multiple choice test? Did you use any of the strategies above? Do you have other strategies that work well?



JOB TASK FOUR: Answering Multiple Choice Questions

Answer the following questions. You will need to refer back to the reading on **Types of Foodborne Illnesses**.

- 1 If you want to prevent E. coli infection, you should:
 - a) Wash your hands using soap and water
 - b) Cook food thoroughly
 - c) Drink pasteurized milk
 - d) Drink water from a safe supply
 - e) All of the above

- 2 The most common symptom of bacterial intoxication is:
 - a) Cramps
 - b) Diarrhea
 - c) Vomiting
 - d) Headache
 - e) None of the above

- 3 The symptoms of Salmonella occur:
 - a) Within a day
 - b) Right after eating meat products
 - c) 12 hours after eating
 - d) 6 to 72 hours after eating
 - e) All of the above

- 4 E. coli bacteria can be found in:
 - a) Contaminated water
 - b) Unpasteurized milk
 - c) Raw meats
 - d) All of the above
 - e) None of the above

- 5 If you want to prevent Staphylococcus Aureus, you should:
 - a) Cook food thoroughly
 - b) Only eat food cooked by yourself
 - c) Practice good personal hygiene
 - d) A and C
 - e) B and C



OVERTIME ACTIVITY: Reading Strategies

Would you like more information on reading strategies? Go to the Study Guides and Strategies website.

www.studygs.net/crtread.htm

- 1 Learn about the SQ3R (survey, question, read, recite, review) reading method.
- 2 Read about the KWL (what we **Know**, what we **Want** to know and what we **Learned**) reading and studying method.
- 3 Learn more strategies for reading difficult material.

Performance Review

In this chapter you have worked on reading skills necessary for longer, complicated documents. You also learned some studying and test-taking strategies. How do you think you did? Use the chart below to reflect on your improved ability to use reading skills for work.

Essential Skill	Exceeds Expectations	Meets Expectations	Needs Additional Training	LBS	ES
Reading					
I can skim and scan for information.				2	1
I can read longer, more difficult texts for single pieces of information.				3	2
I am able to distinguish between relevant and irrelevant information.				3	3
Other Essential Skills					
Document Use					
I can organize information in a chart.				2	1
I know how to use a Table of Contents.				1	1
I know how to use a Glossary.				2	1

CHAPTER 4

Maria Reads

Warm-up for Work

Are you ready for these employment-based reading activities? Get a head start by reading these two questions. Then have them in your mind as you work through the material.

- 1 How can I use information on National Occupational Classifications (NOC) for my own job search?**
- 2 How can I use job ads to help me prepare for my job search?**

Rate yourself on the skills employers want.

Employability Skills	I have this skill.	I am not sure.	I need to work on this skill.
I am familiar with NOC codes.			
I can find relevant information by scanning the NOC.			
I am familiar with ES Profiles.			
I can find an ES Profile that is close to the job I would like.			
I can organize information into a chart.			
I can search the Internet for information.			

Part One



Job Shadowing

Maria has been working hard at the Centre for Upgrading and Essential Skills (CUES) for close to four months. Her skills have improved, and now she is looking forward to finding a job in home care.

“I think I’m ready to start looking for a home care job,” Maria told her husband Vince. They had just finished eating supper. Vince’s face wore a contented expression. Maria had made one of his favourite dishes: chicken Parmesan.

Over the past four months, Vince had gotten used to the idea of Maria working outside the home. Since Maria had been attending CUES, she was much happier. Vince had a hard time explaining it, even to himself, but Maria seemed to be more confident somehow.

So now Vince said, “Great! Uh, where do you find that kind of work anyway?”

“There are lots of home care organizations in the community,” said Maria. “I am sure that one of them will want to hire me!”

The next day, Maria discussed her plans with her instructor, Lisa.

“I think you’re ready to begin looking for work,” Lisa agreed. “Why don’t you start by reviewing the NOC code for the job you are interested in, and we’ll take it from there?”



JOB TASK ONE: Finding and Reading NOC Codes

NOC stands for National Occupational Classification. Thousands of jobs have been classified by their NOC codes. Why are these important? There are a number of reasons.

- ▶ The NOC organizes the world of work in a standardized and structured format.
- ▶ It provides descriptive information about occupations in the Canadian labour market.
- ▶ The NOC helps job seekers by giving full descriptions of jobs and linking them to the most important Essential Skills required for jobs.

“Where do I find NOC codes?” wondered Maria.

Help Maria find the information she needs.

Step One	Using Google , enter NOC codes in the search bar. Click on pages from Canada. Click on National Occupational Classification 2006. It will probably be the first option given. Once you are on the webpage, click on the link to the National Occupational Classification 2006.
Step Two	Enter Maria’s job title, Home Care Worker, in the Quick Search Box . Don’t forget to click Go.
Step Three	Click on the 6471 NOC code . It should take you to the following website. http://www5.hrsdc.gc.ca/NOC/English/NOC/2006/ProfileQuickSearch.aspx?val=6&val1=6471&val65=Home+care+worker

Print out the NOC code for Maria’s occupation: home care worker

- 1 Highlight or underline the skills, education and experience needed to be a **visiting homemaker**. **Keep this document for your final job task.**
- 2 Return to the NOC website. Choose an occupation that interests you and print it out. Underline or highlight the skills, education and experience needed for your chosen occupation.

“This is very clear,” said Lisa when Maria had shown her the printed out pages for a visiting homemaker. “Now how about looking up the Essential Skills needed for Visiting Homemakers?”



JOB TASK TWO: Finding and Reading Essential Skills Profiles

Essential Skills are the skills needed for work, learning and life. The Government of Canada and other agencies have identified nine **Essential Skills**. We use these nine skills at work and in our daily life. **Essential Skills Profiles** describe how each of the nine Essential Skills is used by workers in over 300 jobs.

Help Maria find the profile for **Visiting Homemakers**. You can search for a job profile in several ways. If you do not know the NOC code, you can use job title, key word or specific skills. It is easiest to use the NOC code if you know it. Once you start checking out the NOC codes, you will learn that one job may be classified under several different titles. This is true for Maria: personal support worker, visiting homemaker and home care worker come under the same NOC code.

Step One	Use Google to locate the Essential Skills Website
Step Two	Click on Essential Skills — Home
Step Three	Click on Search job profiles
Step Four	Click on NOC
Step Five	Enter Maria's NOC code
Step Six	Take a look at the reading tasks for Visiting Homemakers inserted below

A. Reading Text

Tasks	<u>Complexity Level</u>	<u>Examples</u>
<p><u>Typical</u></p> <p><u>Most Complex</u></p>	<p>1 to 3</p> <p>1 to 3</p>	<p>Visiting Homemakers, Housekeepers and Related Occupations:</p> <ul style="list-style-type: none"> • read memos from members of the health-care team and notes from the client or the client's family. (1) • may read recipes to prepare food which clients request. (1) • read newspapers and letters to the patient. (2) , (frequently) • may refer to orientation material and regulations on procedures, policies, behaviour and safety requirements set forth by home care agencies or foster parent agencies. (2) • read newsletters from social service agencies or associations announcing workshops. (2) • read reports from agencies outlining policy changes. (2) • may read notes from a foster child's case file about the child's background, medical history, mental health and special needs. (2) • read first-aid manuals. (3) • read text books, pamphlets and journal articles to learn more about health issues such as chronic diseases, mental disorders, exercise and nutrition. (3)

The most difficult reading tasks are shown as (3) while the easiest reading tasks are (1).

- 1 Highlight the main reading tasks for Visiting Homemaker. The first one is done for you.
- 2 Look at the full profile. Print out the **two most important** Essential Skills for personal support workers. (Hint: They are listed first.) Highlight the main tasks for each skill. **Keep this document for your final job task.**
- 3 Follow steps one to six on the previous page. At step five, enter the NOC code of your chosen occupation instead of Maria's.
 - a) Write out the main reading tasks of your chosen occupation.
 - b) List the most important Essential Skills for your occupation.



Maria scrolled down through the NOC and Essential Skill information. What a lot of material! I think I'd better print this out, Maria thought to herself.

After she had printed out the pages, Maria read them carefully. As she read, she used a highlighter to highlight important points for her job search. She made some notes when she read important information.

After Maria had finished, she looked over the printed pages. Now they were coloured with yellow highlighter and her notes were made neatly in the margins. Maria could clearly see that while she studied at CUES, she had been working on important Essential Skills for home support workers.

"It was a very good idea to print out this information," said Lisa, the instructor. "What's the next step?"

"Well, I thought that I would look at some job ads," said Maria.

"Good plan. Then you will be able to take the NOC and Essential Skills information and compare it to what employers say they are looking for."

Part Two



Job Shadowing

Maria decided that she would start with the newspaper and see whether or not there were any job ads for home care workers. She looked carefully through the want ads. There were several for home care, but they required nursing. Finally, Maria found an ad that was seeking a personal support worker.

That's me! Maria thought to herself happily. Carefully, she cut the ad out of the paper.

Job Opportunity

Personal Support Worker

Under the general direction of the Home Support Supervisor/Manager, and the clinical direction of a health care professional, provides home support services to clients by assisting with activities of daily living such as bathing, grooming and oral hygiene while promoting maximum independence. Performs delegated tasks according to written procedures for which training has been completed and in accordance with the Interior Health Personal Assistance Guidelines.

Qualifications:

- At least one year of recent personal care experience in a similar position or life experience in which similar duties were completed
- A solid knowledge of the principles, practices and methods of community nursing and the delivery of personal care service to clients
- Ability to communicate in English verbally and in writing, ability to speak Spanish an asset
- Exceptional interpersonal skills and ability to work independently and as part of a team
- Able to stand, bend, squat, kneel and reach freely
- Able to lift 23 kilograms
- Able to assist clients with standing, walking, sitting and rolling in bed
- Demonstrated ability to follow written and verbal instructions as related to client care
- Able to travel locally from assignment to assignment

Education

Apply in writing to Community Health Manager, Fenton Health Services, 501 Main Street, Suite 303, Fenton, ON, M3W 3P2

Next, Maria thought that she would visit the Job Bank. There were a number of job ads for home care workers. Again, many requested nursing certification, but some did not. Maria printed out one for a job in her community.

TITLE: Personal Support Worker (Health Care Aide/ Home Care Worker Support Worker) (NOC: 6471)

Terms of Employment: Casual, Part Time, On Call, Shift, Weekend, Day, Night, Evening

Salary: To be negotiated

Anticipated Start Date: As soon as possible

Location: Fenton, Ontario (2 vacancies)

SKILL REQUIREMENTS

Education: Completion of high school

Credentials (certificates, licences, memberships, courses, etc.): First Aid Certificate, Health Care Aid Certificate, Nursing Aid Certificate, Home Support Attendant Certificate, Personal Support Worker Certificate

Experience: Experience an asset

Languages: Speak English, Read English, Write English, Speak Italian, Spanish or Portuguese an asset

Type of Clientele: Convalescent, Seniors, Elderly, Persons with a mental health disability, Terminally ill, Female, Male

Specific Skills: Prepare, cook and serve meals, Launder clothing and household linens, Perform light housekeeping and cleaning, Provide personal care, Provide companionship, Care for individuals and families, Administer bedside and personal care, Assist clients to walk, Aid clients with bathing and other aspects of personal hygiene

Work Location Information: Work in employer's/client's home, Urban area, Various locations

Transportation/Travel Information: Own transportation, Own vehicle

Essential Skills: Reading text, Document use, Numeracy, Oral communication

Other Information: Required Immediately: Home Care Worker/PSW/Care Giver for p/t casual work in urban Fenton. Criminal Check mandatory. If you are looking for light work, with short hours, please contact us immediately.

Employer: Constant Care Health Services Inc

continued on next page...

HOW TO APPLY

Please apply for this job only in the manner specified by the employer. Failure to do so may result in your application not being properly considered for the position.

By E-mail: stephaniecompassionatecare@yahoo.ca

Advertised until: 20__/09/30

This job advertisement has been provided by an external employer. Service Canada is not responsible for the accuracy, authenticity or reliability of the content.

Maria decided to search for a few more job ads. She knew that some of the larger companies have websites that post jobs. She decided to check out some of these.

Maria now had a thick pile of job search information. She flapped the papers at Lisa.

“Look! All of this information on home care workers! I am sure to find a job! Look at this one,” she said as she shuffled through the pages. “It lists the Essential Skills for a home care worker — and speaking Spanish is an asset!”

Lisa said, “That is good news, Maria. You seem to have a really good sense about what employers are looking for in a home care worker.”

“Yes, I have all of this information...I’m just not sure what to do with it,” said Maria.

Lisa laughed.

“I think there is only one piece missing from the puzzle now,” she said. “You need to make sure that you have the skills, experience and education that employers are looking for. Things are getting pretty complicated with all of the papers you have printed out. Why don’t you create a chart that organizes your information? Then you can see more clearly where your skills, education and experience fit in with what employers are looking for. Then I think you can begin work on your résumé.”



JOB TASK THREE: Comparing the NOC, Essential Skills and Job Ads

Before Maria begins work on her résumé, she needs to be sure that she is giving employers the information they need and want. Maria has much of the material she needs in

- ▶ NOC 6471, the description of a home care worker
- ▶ The Essential Skills Profile for NOC 6471
- ▶ The employers' job ads

- 1 You already have the NOC description and the Essential Skills Profile for NOC 6471 that you saved from your previous two job tasks. Now you are ready to compare these to the employers' job ads.

Using the chart on the next page, record

- ▶ Main duties as outlined in the NOC 6471 information
- ▶ The most important Essential Skills
- ▶ The skills, experience and abilities that each employer is looking for
- ▶ The main duties and Essential Skills that are also mentioned in the job ads

- 2 Following the same steps as you have with NOC 6471, compare the NOC description and the Essential Skills for a job of your choice with employers' job ads. You can search for job ads in your local paper and on the Job Bank website. The link to the Job Bank is below. A second chart is on page 95.

www.jobbank.gc.ca/

- ▶ Find the NOC code for a job you are interested in.
- ▶ Find the corresponding Essential Skills Profile.
- ▶ Search the Job Bank or your local paper for job ads.

When Maria had completed her chart, she had all of the information she needed organized in one place. Now she knew the Essential Skills and other employment requirements for a home care worker.

“This will be much easier to work with,” she said to Lisa.

Lisa agreed.

“When everything is organized like this, you are less likely to overlook something important,” she said.

Maria nodded. Now she was ready to compare her own skills, experience and education with her chart. She could be confident that her résumé would soon have the information that employers wanted and needed.



OVERTIME ACTIVITIES: Essential Skills and Jobs

Are you interested in more reading-related work activities? Check out the activities below for more practice.

- 1 Check out the information on 120 entry-level jobs at <http://www.mygates.ca/index1.html>. Click on job seekers. Next, click on jobs. Choose a job that interests you and read about the Essential Skills required to work in that career. Click on training plans to access a personal training plan. You must first register on the site to access your training plan.
- 2 Go to the Essential Skills Portfolio website and check out some of the activities which will help you prepare for an entry-level job: <http://www.esportfolio.com/ESPORT/english/>. You can start by taking an interest inventory. Or maybe you already know what kind of work you want to do; in that case, assess your Essential Skills and check out job opportunities. You will also need to register on this site before using all the available information.

Performance Review

In this chapter you have worked on essential reading skills for work. How do you think that you did? Use the chart below to reflect on your improved ability to use reading skills for work.

Essential Skill	Exceeds Expectations	Meets Expectations	Needs Additional Training	LBS	ES
Reading					
I can skim and scan for information.				2	1
I can read simple texts for several pieces of information.				3	2
I can interpret information from three different texts.				2/3	3
I can integrate information from three different sources.				3	3
I am able to distinguish between relevant and irrelevant information.				3	3
Other Essential Skills					
Computer Use					
I can search for information on the Internet.					1
Document Use					
I can organize information in a chart.					1

EmployAbility SUCCESS!

MODULE 2

Ready for Document Use at Work

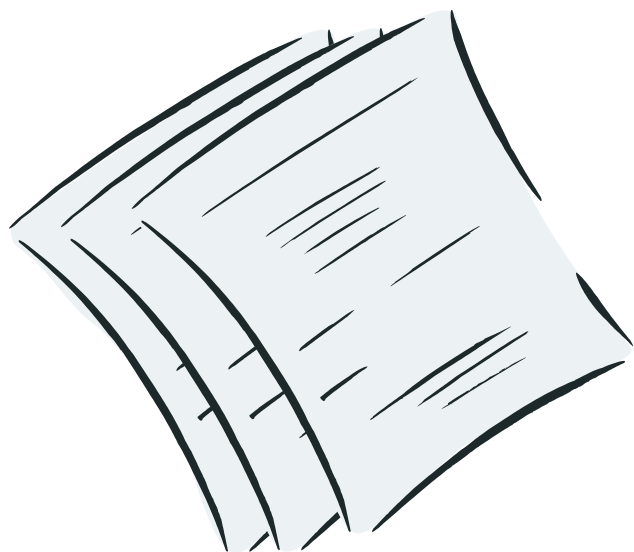

CHAPTER	TITLE	PAGE
–	Practitioner Guidelines	100
–	Student Guidelines	115
1	Erica Uses Documents	117
2	Maria Uses Documents	129
3	Jerry Uses Documents	139
4	Keith Uses Documents	149

Practitioner Guidelines and Answer Key

Overview of Module Two — Document Use

Module Two consists of four chapters, each one providing students with opportunities to improve their Document Use skills. The format corresponds to Module One. Students will be working with the following documents in this module:

- ▶ Information posters
- ▶ Special offer coupon
- ▶ Sales flyer
- ▶ Purchase order, both paper and online
- ▶ Packing slip
- ▶ Daily log
- ▶ Medication package
- ▶ Bulletin board notice
- ▶ Pay cheque
- ▶ Pay stub
- ▶ Timesheet
- ▶ Safety meeting information

As with the previous module, please review all the chapters and the guidelines before beginning instruction. You are encouraged to supplement the documents with additional ones that may be of particular interest to your students.

Chapter-Specific Instructions and Answer Key

CHAPTER ONE — Erica Uses Documents

In Chapter One, students will encounter an information poster and a special offer coupon. The goal in these activities is for students to learn to navigate each document. Knowing how documents are set up and understanding how each part functions makes for easier understanding.



Do you agree with Erica? Is it silly to have a poster telling you how to wash your hands? Why or why not?

- 1 This question icon is meant to encourage students to think about the importance of hand washing. Discuss the reasons why it is important to wash their hands often during their day-to-day activities. Be prepared to provide numerous workplace examples where it is critical that staff wash their hands. Examples would be the food industry (including grocery workers, restaurant wait staff and kitchen staff), retail, banking, and so on. How long should you scrub your hands? Most health professionals recommend 15 seconds, roughly the length of time it takes to sing the Happy Birthday Song.



Why do you think that many city health departments are issuing instructions on hand washing?

Be sure to mention the transmission of disease, particularly flu. The recent SARS and H1N1 epidemics have resulted in health departments raising the issue of hand washing. The presence of hand sanitizers in workplaces is now commonplace.



JOB TASK ONE: Hand Washing Poster

Students should notice the distinct parts of the poster—coloured section with photos, side bar, and key message. Point out the use of colour and large bold titles.

- 1 The main section (coloured section with photos) provides a step-by-step procedure on how to carefully wash your hands.
- 2 The side bar (Other tips) provides more information on hand hygiene, including increased bacteria with artificial and chipped nails.

Although not mentioned in this poster, health officials also recommend short nails and no rings or jewellery. **Why?** Germs and bacteria can get trapped there, and hand washing may not be enough to prevent contamination.

- 3** Students should say the coloured portion with photos. It appears more important due to:
- ▶ Large titles
 - ▶ Use of colour
 - ▶ Photos
 - ▶ Central location of information on poster

As well, the side bar is titled “Other tips,” which indicates that they are secondary to the main message.

Workplace Know-How

Encourage students to read the Workplace Know-How section. The information provided in it is essential for the next task.



JOB TASK ONE: Part Two

- 1 The poster is about Handwashing.
- 2 The central message is How to Properly Wash Your Hands.
- 3 The key information provided is a step-by-step method with photos, demonstrating proper hand washing.
- 4 The additional information provides suggestions for preventing the spread of bacteria and infections.



JOB TASK TWO: Safety Poster

Students will need to apply the same information from the Workplace Know-How section to answer these questions.

- 1 The poster is about Pick Up Tips.
- 2 The graphics — including photos, large titles, the use of colour, the use of short phrases
- 3 There are at least six things you should consider before lifting — get a good grip, keep it in the middle, try not to bend, keep it close, slide and tighten and step or pivot.

The central message in this poster is less obvious, but some students might remark on the title of the textbox — Plan and Prepare — which is essential to proper lifting.



Job Shadowing: Reading Discount Coupons

You may wish to bring in additional coupons to provide more examples for your students. The first coupon in the scenario is printed quite small. Students will likely have a difficult time reading it. This is intentional because many coupons and special offers put the restrictions in very small print.



What do you think that Erica should do?

Students should notice the time and date at the bottom of the coupon. Erica should inform the customer that the coupon is not good until February 1st.



Why do you think that people aren't reading the date?

The print is very small.



Have you any suggestions for Edna and Sam?

Answers will vary, but enlarging the print is the most likely answer.



JOB TASK THREE: Coupon

- 1 a) offer available Monday to Friday
- b) between 7 and 11 am
- c) from February 1st to February 28th
- d) must buy a muffin to get a free coffee

**OVERTIME ACTIVITY ONE: Coupon**

- 1 Must spend \$25 to receive a free ham
- 2 Only available to first 25 customers
- 3 Only valid on Saturday, December 19th

**OVERTIME ACTIVITY TWO: Safety Poster**

- 1 Safe knife handling
- 2 Easy Do's and Don'ts for safe knife handling for teens
- 3 Answers may vary but students should consider the large numbers of teenagers working in the food sector at fast food restaurants. It is also important for teens who may be taking cooking classes as part of their high school curriculum. Many teens also volunteer in soup kitchens.
- 4 Answers will vary, but one possibility is that you are more likely to cut yourself if you are distracted by talking to someone while you are using a knife.

CHAPTER TWO — Maria Uses Documents

In Chapter Two, students will be using the following documents:

- ▶ A daily log report
- ▶ A medication blister pack



Have you ever had a job interview? What went well in your interview? Do you have advice for someone who is preparing for an interview?

For most people, job interviews are stressful experiences. Reassure students that most people are nervous for a job interview. Being well prepared can help to eliminate some of the anxiety. Encourage students to share any relevant experiences and suggestions. Perhaps you can share some of your own interview experiences. The job interview tips are there for information only. Numerous resources and websites are available for those wishing more in-depth knowledge.



Why do you think Maria must not make any statements about their clients' health?

Maria is not a qualified medical staff person. This is a good opportunity to discuss the importance of knowing when you should let someone else do a job task. If you are not qualified or trained in a certain area, let the appropriate person take on that task.



JOB TASK ONE: Fill in a Daily Log

The answers will vary. Not every activity will involve an expense. If they go to Tim Hortons for coffee, the expense would be their purchase. Going to class might involve bus fare or a parking expense.



Do you think it would be useful to keep a log of your day-to-day activities? Why or why not?

Possible responses might include:

- ▶ It is useful to track your expenses, particularly if you are on a budget.
- ▶ It will help to gauge how much time you spend on certain activities.
- ▶ Tracking activities might indicate where you can save time and money.
- ▶ Keeping a log can be useful if you are watching what you eat and how much you exercise. Maybe you are spending too much on coffee or too much time on the Internet, or you are eating too much junk food!



JOB TASK TWO: Using a Medication Blister Pack

- 1** Students should look in the column under the heading **Meds Given?** The log should look like the one on the next page. Students should also highlight meds information in the activities column.
- 2** For the morning blister pack (am), the 28th and 29th should be filled in. For the afternoon blister pack (pm), the 27th, 28th and 29th should be filled in.
- 3** The completed blister packs should look like the ones following the log on the next page.

Date	Meds given?	App't	Activities
27/06	Yes, 12 pm		Helped Freda with bath
11-3 pm			Made her lunch and helped her eat (Good appetite today!)
			Read to her from Bible and novel
			Walked down the street and watched children at park
28/06	Yes, morning	Hair	Helped Freda wash and dress
9-1 pm	Yes, 12 pm		Drove her to Napoli Hair Stylists for appointment
			Went to Tim Hortons for a bowl of soup and cookie (4.95)
			Home by 12. Did not want to take meds (too tired, she said)
			Gave her meds and helped her to lie on sofa with a blanket
29/06	Yes, morning	Doctor	Helped Freda shower and dress
9-1 pm	Yes, noon		Drove to Dr. Mendoza's office
			Filled new prescription at drug store
			Made lunch at home. Freda not very hungry
			Had meds
			Asked me to read, but fell asleep
			Does not seem as alert as usual

MORNING
START ON DAY

DAYS OF THE MONTH

AFTERNOON
START ON DAY

DAYS OF THE MONTH



OVERTIME ACTIVITY: Weblogs

Encourage students to find blogs on a variety of topics, depending on their interests. Share any good blogs you might know of. Students may wish to register to join a blog.

CHAPTER THREE — Jerry Uses Documents

In Chapter Three, students will encounter the following documents:

- ▶ A purchase order
- ▶ A sales flyer
- ▶ A packing slip
- ▶ A manufacturer's website

The most critical information for students in this chapter is the importance of accuracy. Figures need to be rechecked because it is very easy to enter numbers incorrectly. Documents such as these also often have “small print.” Remind students to review their work as they would on the job.



JOB TASK ONE: Reading a Sales Flyer



What does Jerry need before filling in the purchase order?

- 1 He needs the catalogue in order to include the part numbers.
- 2 He needs the sale price because the trade show flyer is offering 25% off.
- 3 He needs to know that prices are in effect only until July 15th.
- 4 He needs to know the manufacturer will also match competitors' prices.

Why is it a good idea to keep a copy of your purchase order?

Possible responses might include:

- ▶ In case the manufacturer loses your order
- ▶ To compare with the shipment when it arrives



JOB TASK TWO: Using a Purchase Order



What special instructions are included on the purchase order for the supplier?

You can find the special instructions at the bottom of the purchase order in small print.

- 1 Send two copies of the invoice.
- 2 Enter order in keeping with prices, terms, delivery method and specifications listed above.
- 3 Notify immediately if unable to ship as specified.
- 4 Send all correspondence to Randy Spenser.



What do you think “authorized” means on the purchase order? Why do you think this is important?

“Authorized” means that your actions have been approved by a supervisor or someone with more authority than you have.

Authorization ensures that an employee’s actions are in keeping with company policy. Once a supervisor checks your work and authorizes it, the supervisor becomes responsible for what follows.



JOB TASK THREE: Checking an Order



Why do you think Jerry should compare the shipment with the packing slip and the purchase order?

- ▶ The entire order might not be shipped.
- ▶ Some items might be on back order, in which case the manufacturer may provide a shipping date.
- ▶ Some items might not be included and yet you are charged for them.
- ▶ There might be an error in the item number or the cost.
- ▶ Sometimes the wrong item has been shipped.

1 The shipment is not correct. The packing slip should look like the one below.

2	291932-2	½" Scale Torque Wrench	14.37 ✓
6	715651-1	10A Battery Charger	27.32 ✓
6	824887-1	Electric Paint Spray Gun	21.50
B/O	209004-2	2 Ton Jack Stands	14.39
1	500394-1	1 Ton Transmission Jack	299.50

- ▶ The first two items are correct and should be checked off.
- ▶ The price is wrong for the third item. It should be \$17.50 each.
- ▶ The fourth item is on back order.
- ▶ The fifth item has the wrong item #. It should read 500384-2. The item description is wrong. It should be 1000 lb folding engine stand. Finally, the price should read \$78.50, not \$299.50.



What do you think Jerry should do about the errors on the purchase order?

Answers ought to include:

- ▶ Let Randy know about the errors right away.
- ▶ Tell Ace Auto Parts about the errors.



OVERTIME ACTIVITY: Filling in a Purchase Order

Answers will vary depending on the items the students select. Students will need to click on each item in order to get all the information they require. You may wish to check that the purchase orders are filled in correctly the same way a supervisor might. You can then authorize correct work with your initials.

CHAPTER FOUR — Keith Uses Documents

In this chapter, students will encounter these documents:

- ▶ a bulletin board notice
- ▶ a pay cheque and pay stub
- ▶ a timesheet
- ▶ a safety information flyer

You may wish to provide additional notices and/or announcements.

Toolbox Meeting Notice: Point out the use of bold and the headings to students to get them thinking about how to look for important information.



What could happen if you don't check the staff bulletin board every day?

Answers will vary. Students should mention the importance of staying informed about upcoming events and meetings. If you have a bulletin board in your workplace, you may want students to look at it to see the kinds of information found on it. Are some items more important than others? How can you tell?



JOB TASK ONE: Meeting Announcement

- a) What — Toolbox Meeting
- b) When — Monday, January 25, 2010
- c) Time — 7 am
- d) Where — Main Office Boardroom
- e) Topic — Asbestos



JOB TASK TWO: Toolbox Meeting Guide

Page two of this document is a sign-in sheet. Students will need to check this over in order to correctly answer questions one and two.

- 1 Employees are encouraged to participate, as shown by the space provided for crew members to make suggestions on safety issues.
- 2 Students should highlight the section which records who attended the meeting.

Ask students why they need to both print their name and give their signature. (This ensures that no one else can sign in for them as well as making sure supervisors can read their name properly.)

Employers require this information so they can keep track of those who have received important training. They can ensure that anyone who was absent will receive the same information later. In some cases, Occupational Health and Safety and the Ministry of Labour may require that employees receive certain safety information along with training.

- 3 The only construction workers who will encounter asbestos are those who are renovating or demolishing older houses. Asbestos is no longer used in home construction.



JOB TASK THREE: Reading a Pay Cheque

- 1 The cheque stub should look like this:

Straight Path Construction		Cheque No.	301
Keith Jenkins	July 30, 2010	For Pay Period July 26, 2010	
Regular.....	820.16	CPP	15.78
Vacation	82.02	El.....	15.60
Gross.....	902.18	Tax	122.00
		Union Deduct	72.16
		Withheld	225.54
			Gross.....902.18
			Withheld.....225.54
			Net.....676.64
			Regular: 44 hours @ \$18.64

- 2 Union deduction
- 3 44 hours
- 4 \$18.64

Workplace Know-How



You may want to go over the terminology on the pay stub with students. (Gross pay versus net pay, regular and vacation pay, mandatory deductions, etc.)



JOB TASK FOUR: Reading a Timesheet

- 1 The timesheet is for the month of July only. July 1st and 2nd fall on Thursday and Friday.
- 2 In week 5, the two nines were read as sevens. These two numbers should be highlighted.



OVERTIME ACTIVITY: Toolbox Meeting Guide — Noise — how loud is it?

- 1 The document is about noise.
- 2 Its central message is about noise-induced hearing loss and the importance of protecting your hearing.
- 3 Jackhammer operator
- 4 Earplugs + earmuffs



Do you know of anyone who has hearing loss as a result of their job? What other occupations besides construction require workers to use hearing protection devices?

Possible answers include heavy equipment operators, manufacturing/factory jobs, saw mill jobs.



You can also suffer hearing loss outside of work. Can you think of ways this could happen?

Listening to loud music, attending rock concerts, using ipods...

Module 2 — Student Guidelines

Ready for Document Use at Work

Welcome to Document Use on the Job. This module will help you to learn and practice many activities for using documents in the workplace.

Document Use is different from simple reading or writing. When you read something like a newspaper article, you usually read sentences and paragraphs for information. When you write something like a letter, you write in sentence and paragraph form too. With Document Use, you need to do some reading, but you also have to look for graphics and other visual clues to help you understand the document. If you are required to write on a document, the entries are usually very brief. They can be single word entries, point form or short sentences. Sometimes, documents need to be filled in with numerals as well.

When using documents, keep these tips in mind from Human Resources Development Canada's Essential Skills website:

General Tips

- ▶ Use your finger or a ruler to follow rows or columns in a table.
- ▶ Use headings to find information quickly.
- ▶ Look for visual cues such as font size, bolded or highlighted text that may emphasize important information.

- ▶ Look for characters or symbols which may provide special instructions (e.g., asterisks).
- ▶ Write legibly and stay within the allocated spaces.
- ▶ Use words that are easy to read and understand when entering information.
- ▶ Scan documents several times to ensure the information you have entered is complete and accurate.
- ▶ Read instructions carefully before completing forms or questionnaires.
- ▶ Complete documents in the recommended order.
- ▶ Read labels and headings carefully before entering information.
- ▶ Identify common shapes and colours to help understand signs and symbols (e.g., diamond represents warnings; red represents danger or stop).
- ▶ Ask questions if you do not understand what you see on a sign, display or document.

(from: www.hrsdc.gc.ca/eng/workplaceskills/essential_skills/doc_use_tip_sheet.shtml)

Almost all jobs require you to use documents:

- ▶ Home care workers need to fill in logs and read medication instructions.
- ▶ Food service workers need to read coupons.
- ▶ Workers in retail or shipping and receiving need to use packing slips and invoices.
- ▶ Construction workers need to read timesheets.
- ▶ All employees should know how to read their pay cheques.

You have probably improved your ability to use documents to prepare for employment. In this module you will be using documents similar to many found in the workplace.

In Chapter One, Erica reads the information on a workplace poster about hand washing. With all of the concern around influenza (H1N1), Erica thinks that it might be a good idea for her to make sure that she is following all of the steps for effective hand washing.

Erica also needs to read a Dough Dude Bakery discount coupon that a customer wants to redeem.

In Chapter Two, Jerry uses a sales flyer to help him place an order with a supplier. Then, he needs to check off the packing slip to make sure the order is correct.

In Chapter Three, Maria is working as a home care companion at Home Sweet Homecare. She needs to fill in a daily log report to record her activities with her client. She also needs to read a medication blister pack to make sure that her client takes her meds at the right time.

In Chapter Four, Keith attends a toolbox meeting at Straight Path Construction and reads a document on safety and working with asbestos. Then he double checks his pay stub and discovers an error in his pay cheque amount.

As you work through the chapters, remember that Document Use is an Essential Skill. This means that regardless of your job, the skill of using documents is essential; you can't get by without it! The activities in this chapter will allow you to practice typical workplace Document Use tasks. The questions you answer are about the kinds of situations that occur in the workplace. You can work through the activities and questions at your own pace. As you work through each chapter, you can be confident that you are improving your employability skills as well as your chances of getting the job you want.

CHAPTER 1

Erica Uses Documents

Rate yourself on the skills employers want.

Employability Skills	I have this skill.	I am not sure.	I need to work on this skill.
I know how to read an informational poster.			
I can read and understand a promotional coupon.			



Job Shadowing: Reading a Hand Washing Poster

When Erica arrived at work on Tuesday morning, she was surprised to see all the lights on. Usually, Sam came in by himself on Tuesdays. He worked in the back and Erica opened the bakery counter. She would turn on the lights, take the cash float from the safe and put it into the cash register. Then she would begin to fill up the bins with muffins, bagels and rolls. This morning, however, Edna had come into work as well, instead of taking the morning off.

“Hi Edna, how are you today?” Erica asked.

“I’m fine, but Susan called me last night. She has the flu and won’t be in today. She probably won’t be in for the rest of the week!”

“Oh no! My mother just got over it; she was sick for a week and a half,” said Erica.

“Well, we don’t want it spreading around here. We can’t be too careful when we are dealing with so many customers,” said Edna. “As a matter of fact, I just received new hand washing instruction posters in the mail yesterday. You can tape one up in the washroom and another one over the deli sink.”

Erica didn’t reply. She thought it was a bit silly to have a poster telling you how to wash your hands.

Edna gave her the posters and a roll of tape.

“You may as well do it now,” she said.



Do you agree with Erica? Is it silly to have a poster telling you how to wash your hands? Why or why not?



Why do you think that many city health departments are issuing instructions on hand washing?

Erica taped the first poster over the deli sink. She was surprised to see that there were so many steps to hand washing. Maybe I'd better read this, she thought.



JOB TASK ONE: Hand Washing Poster

Look at the poster on the next page and answer the following questions.

- 1 There are two parts to the hand washing poster. What kind of information is given in the main section?

- 2 What additional information is found in the side bar (Other tips)?

Pandemic
Planning

HANDWASHING

How to properly wash your hands

Other tips

remove any rings or other jewelry; use warm water and wet your hands thoroughly.



use a sufficient amount of soap (1-3 ml) and lather very well.

lather soap and scrub hands well, palm to palm.



scrub in between and around fingers and back of each hand.

scrub fingertips of each hand and under your nails in opposite palm.



scrub each wrist clasped in opposite hand

rinse thoroughly under running water.



with a paper towel turn off the tap or faucets

dry your hands with a single use towel or air dryer.



protect your hands from touching dirty surfaces while in the washroom and as you leave.

- ✓ Cover cuts with bandages and wear gloves for added protection (cuts are very vulnerable to infections).
- ✓ Artificial nails and chipped nail polish have been associated with an increase in the number of bacteria on the fingernails. Be sure to clean the nails properly.
- ✓ Keep your hands away from your eyes, nose or mouth.
- ✓ Assume that contact with any human body fluids is infectious.

- ✓ Liquid soap in disposable containers is best. If using reusable containers, they should be washed and dried before refilling. If using a bar of soap, be sure to set it on a rack that allows water to drain or use small bars that can be changed frequently.

3 Which part of the poster do you think is the most important section to read? Why?

Workplace Know-How



Information displayed on posters is arranged to make it easy to read and understand.

- Colour is used to attract your attention
- Large bold titles tell you what the poster is about
- Pictures and graphics are used to illustrate key information
- A one or two line key “message” is often included
- Additional or more detailed information is often provided in a box or “side bar”



JOB TASK ONE: Part Two

Take a look at the poster again and, using the information provided in **Workplace Know-How**, answer the following questions.

1 What is the poster about? Look for a large bold title.

2 What is the central message? Look for one or two lines after the title.

3 What is the key information given in the poster? Look for pictures and graphics.

Ergonomics

Pick Up Tips

How to Lift Safely

Plan and Prepare

- Protect your feet and hands with sturdy shoes and work gloves.
- Warm up with gentle stretches.
- Test the load for weight and shifting contents by pulling or sliding it toward you.
- Get help with heavy or awkward loads.
- Keep it on the level. Place loads on a raised platform to avoid bending.

Get a good grip.

Use both hands, and grasp opposite corners.



Keep it in the middle.

Hold the load between shoulder and knee height and don't overreach.



Try not to bend.

If you must, bend your knees to reach or place low-level objects.



Keep it close.

As you lift, keep your back straight and the load close to your body.



Slide and tighten.

Pull the load toward your stomach, tightening the muscles as you get ready to lift.



Step or pivot.

Don't twist or side bend while moving with a load.



- 4 What additional information is provided? Look in the side bar for “other tips.”



JOB TASK TWO: Safety Poster

Answer the following questions, using the poster on the previous page.

- 1 What is the poster about?

- 2 What are two or three things that help to make this poster easier to understand?

- 3 What are six things you need to consider before lifting anything?



Job Shadowing: Reading Discount Coupons

The deli at Dough Dude Bakery was very successful. The lunch hour was extremely busy, and sometimes even Sam had to leave his baking and help out for a half hour. However, Sam and Edna felt that they could be doing more business in the mornings. They decided that they would create a coupon and hand it out to local businesses to generate morning business. The coupon would be valid for one month, so they could see whether or not they had an increase in sales during that time period.



BUY ONE MUFFIN AND GET A COFFEE FREE!

Dough Dude Bakery & Deli

Expires: February 28, 20__

Offer available Monday to Friday from 7 am to 11 am, commencing February 1st, 20__

Erica was working at the bakery counter when she received her first coupon. It was January 29th and very cold outside. One of their good customers, Janet the florist, came in with her coupon.

“This is great! I’m broke until this Friday, but I can still afford a coffee and a muffin with this coupon.”

Janet handed Erica the coupon and looked over the muffins. Erica looked at the coupon in her hand.



What do you think that Erica should do?

“Um, Janet? The coupon is only good for the month of February. I’m sorry, but you will have to wait for three more days.”

“Oh. Does it really matter?” asked Janet, looking unhappy.

“I know that Sam and Edna are very strict about the dates,” said Erica. “They want to measure their sales for one month exactly to see whether or not the coupon is working.”

“Well, I guess I’ll just have a coffee today,” said Janet.

“All right,” said Erica. “And please come back on Thursday with your coupon. I will save you the biggest raisin bran muffin!”

Erica had two more local business people come in with their coupons. Each time she explained politely that the coffee and muffin special began on Thursday, February 1st.

Sam and Edna had left a stack of coupons under the counter for Erica to hand out. Now she took one out and looked at it again. Why aren't people reading the date, she wondered.



Why do you think that people aren't reading the date?

Erica told Sam and Edna that a few people had come in to redeem the coupon.

"That's strange! The date is right on it," said Edna.



Have you any suggestions for Edna and Sam?

Erica said, "Maybe on your next coupon the date should be a bit bigger."

"That's a good idea, Erica," said Edna.



JOB TASK THREE: Coupon

1 Look at the coupon again and list all the restrictions that apply.

- a) _____
- b) _____
- c) _____
- d) _____

Workplace Know-How

Coupons and special offers usually have restrictions about where, when and for how long they are valid. These restrictions are often displayed in small print at the bottom of the coupon.





OVERTIME ACTIVITY ONE: Coupon

1 What are the restrictions on the coupon below?

Free Deli Ham!



At Dough Dude Bakery and Deli

One free Swartz Ham with \$25 purchase.

First 25 customers only!

Valid on Saturday, December 19th.

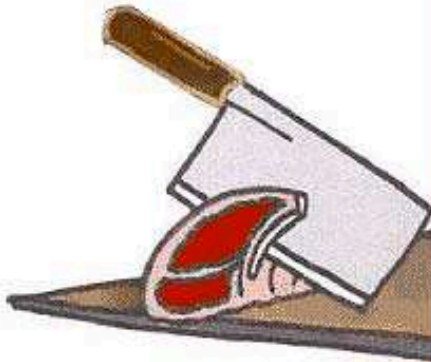

OVERTIME ACTIVITY TWO: Safety Poster

**Easy
Dos and Don'ts****For Teen Workers
- Safe Knife Handling -****Do:**

- ✓ Keep knives sharpened and let other staff know when knives are newly sharpened.
- ✓ Use a knife only for its intended purpose.
- ✓ Use the appropriate knife for the job.
- ✓ Carry knives with the cutting edge slightly away from your body.
- ✓ Store knives properly in racks or knife sheaths.

Don't:

- ⊘ Touch knife blades.
- ⊘ Try and catch a falling knife, let it fall.
- ⊘ Hand a knife to someone. Put it down on the counter and let him or her pick it up.
- ⊘ Leave a knife soaking in a sink of water.
- ⊘ Talk to people while using a knife.

1 What is the poster about?

2 What is the central message?

3 Why do you think that this poster is an important safety message?

4 Why is it unsafe to talk to people while using a knife?

Performance Review

In this chapter you have worked on essential document use skills for work. How do you think that you did? Use the chart below to reflect on your improved ability to use documents for work.

Essential Skill	Exceeds Expectations	Meets Expectations	Needs Additional Training	LBS	ES
Document Use					
I can use a simple informational poster.				2	1/2
I can understand and appropriately use a coupon.				2	1
Other Essential Skills					
Reading					
I can read a short, simple text for two or three pieces of information.				2	1
Thinking Skills					
I can recognize and identify problems.					1

CHAPTER 2

Maria Uses Documents

Rate yourself on the skills employers want.

Employability Skills	I have this skill.	I am not sure.	I need to work on this skill.
I can look up information on the Internet.			
I can fill in a daily log report.			
I can read a daily log report.			
I can read a medication blister pack.			



Job Shadowing: Job Interview

Despite her experience, Maria had difficulty finding a job. Many employers hiring visiting homemakers require their staff to be certified personal support workers. Finally, Maria had phoned her friend Tina, the one whose daughter, Laura, required home care.

“Tina? It’s Maria. I want to find out the name of the company that Laura’s home care aide works for.”

“Just a minute, Ursula’s here right now. I’ll ask her.”

Tina came back to the phone in a few minutes.

“I have the name and number for you,” she said.

“Home Sweet Homecare? I’ve never heard of them,” said Maria, who thought that she had called every home health care provider in the city.

“Ursula says it’s a private company and that the owner is always looking for her to do more hours.”

“Sounds like they might need more people,” Maria said hopefully. When Maria got off the phone, she decided to look up Home Sweet Homecare on the Internet.

“Aha, that’s why I didn’t see it before,” Maria said aloud. “It’s a U.S. based non-medical care service.”

Maria contacted Home Sweet Homecare. She spoke with the owner, Beverly Lake, who arranged to interview her. Maria was very nervous. She took out a book on successful interviews from the library. She looked up interview tips online. She got family members to ask her questions. Maria was well prepared and her interview was successful; she would start the next week.



Have you ever had a job interview? What went well in your interview? Do you have advice for someone to prepare for an interview?

For more information on job interviews, check out Service Canada’s website. The Job Bank contains a number of useful resources for job searchers. The one below includes tips on how to “Ace the Interview.”

www.jobsetc.gc.ca/pieces.jsp?category_id=300&crumb=1&crumb=34&crumb=106



Job Shadowing: Writing a Log

Now Maria has been working as a visiting home companion for just over a month. She takes care of several clients. Mostly, she helps them with their personal care, assisting them to bathe and dress. She puts out food that has been prepared and then tidies up and does the dishes. If her clients need medication, she makes sure that they take it at the right time. Sometimes she goes for a walk with them or takes them to appointments.

When she finishes her tasks, Maria writes down what she has done in the home care log. The home care log is used to record her activities and to make comments on the client, when appropriate.

“Nothing medical!” Beverly said when Maria asked what kinds of comments she should make about the client. “Just whether or not they ate or took their medication. You could say something like, ‘He seems to have less energy today’. Be very careful not to make any statements about their health.”

“The log can be viewed at any time by the client’s family,” Beverly had continued. “Make sure that you record all of your activities with the client so that their families know that you are doing your job!”



Why do you think Maria must not make any statements about clients' health?

Job Interview Tips



There are three parts to a successful job interview:

- Preparing for the interview
- The interview
- After the interview

Preparing for the Interview

- Learn about the position and the company: ask for a job description, talk to people, look up information on the Internet
- Make a list of any experience or background that has prepared you for this job
- Think about possible questions and answers
- Three questions often asked at all job interviews — Why do you want the job? What do you have to offer? What do you want to know about the job? — Prepare answers for these questions.

The Interview

- Arrive a few minutes early
- Be polite to everyone — receptionist, doorman, cleaning staff — everyone!
- Always smile, and give a firm handshake with direct eye contact
- Listen carefully to questions and ask for additional clarification if you need to
- Refer to past work, education, accomplishments, volunteer activities, personal skills, talents
- Be honest as you will be expected to provide real examples
- Ask about the company and at the end of the interview, ask when a decision will be made
- Finally, restate your interest in the job, say thank you and leave

After the Interview

- Send a thank you for the interview
- Do contact the company if you haven't heard anything
- If you don't get the job you might want to call the interviewer to ask how you could improve

Workplace Know-How



Writing a Log

A logbook is a useful tool in many jobs. Keeping an accurate log of your activities lets your employer know that you are doing your job. It helps employers see how you are spending your time.

Logbooks can also benefit you, the employee. For example, if you need to use your own car for your job, you will probably be able to claim for mileage. You can keep a log of how many kilometres you have travelled or how much you have spent on gas.

Depending on why they are being written, logbooks can contain a variety of information. Usually, there is a **column** for each category or heading. For example, “date” and “time” are very common headings.

Normally, you need to give a short description of your activity. The description should sum up your activity accurately but briefly.

BLOG

Did you know that a **Blog** is also a daily log? **Blog** is short for the word **weblog**. It is a type of website that allows a person to make daily entries. It could be in the form of diary entries, articles or even videos. Readers can comment on each entry. **Blog** can also be used as a verb (to blog), meaning to make an entry to a weblog.



JOB TASK ONE: Fill in a Daily Log

Log your activities for one day. Be sure to include times, locations and brief descriptions of your activities. Include any expenses for the day. The first item has been started for you. You can fill in the **day** and **time**.



JOB TASK TWO: Using a Medication Blister Pack

- 1** Go to Maria's log on the next page and see whether or not she has administered any medications. Highlight this information.
- 2** On the blister pack diagrams on the page following Maria's log, colour in the ovals that Maria would have given her client.
- 3** Maria visits this client twice more this week: on Thursday the 30th and on Saturday the 2nd.
 - ▶ On Thursday she is there at 9 am.
 - ▶ On Saturday she is there to help with supper.

Colour in these additional medication ovals that Maria would give her client.

Home Sweet Homecare

Old-fashioned values... Professional care

Daily Care Log

Week: June 27 – July 3

Date	Meds given?	App't	Activities
27/06	Yes, 12 pm		Helped Freda with bath
11-3 pm			Made her lunch and helped her eat (Good appetite today!)
			Read to her from Bible and novel
			Walked down the street and watched children at park
28/06	Yes, morning	Hair	Helped Freda wash and dress
9-1 pm	Yes, 12 pm		Drove her to Napoli Hair Stylists for appointment
			Went to Tim Hortons for a bowl of soup and cookie (4.95)
			Home by 12. Did not want to take meds (too tired, she said)
			Gave her meds and helped her to lie on sofa with a blanket
29/06	Yes, morning	Doctor	Helped Freda shower and dress
9-1 pm	Yes, noon		Drove to Dr. Mendoza's office
			Filled new prescription at drug store
			Made lunch at home. Freda not very hungry
			Had meds
			Asked me to read, but fell asleep
			Does not seem as alert as usual

Medication Blister Packs

MORNING
START ON DAY

DAYS OF THE MONTH

1	8	16	24
2	9	17	25
3	10	18	26
4	11	19	27
5	12	20	28
6	13	21	29
7	14	22	30
	15	23	31

AFTERNOON
START ON DAY

DAYS OF THE MONTH

	8	16	24
1	9	17	25
2	10	18	26
3	11	19	27
4	12	20	28
5	13	21	29
6	14	22	30
7	15	23	31



OVERTIME ACTIVITY: Weblogs

- 1 Find a blog on a topic that interests you. Go to Google.com and enter your topic into the search bar followed by the word “blogs.” For example, if you are interested in cooking, try “cooking blogs.”
- 2 Try this! Put “hockey blogs” into the search engine Google. Choose one of the options. Try Puck Update which provides NHL information. The “Hockey Writers” requires that you sign in before gaining access to their blog.
- 3 If you want to add a comment on a blog, you will likely have to sign in and provide an email address. If you do this, choose a user name different from your own.

Performance Review

In this chapter, you have worked on essential document use skills for work. How do you think you did? Use the chart below to reflect on your improved ability to use documents for work.

Essential Skill	Exceeds Expectations	Meets Expectations	Needs Additional Training	LBS	ES
Document Use					
I can enter information into a daily log.				2	1/2
I can read a daily log report.				2	1
I can read a simple medication blister pack.				1	1
Other Essential Skills					
Computer Use					
I can carry out simple searches for information.					1

CHAPTER 3

Jerry Uses Documents

Rate yourself on the skills employers want.

Employability Skills	I have this skill.	I am not sure.	I need to work on this skill.
I can read a sales flyer.			
I can read and understand a purchase order.			
I can read and understand a packing slip.			
I can fill in a purchase order.			
I can locate a manufacturer website.			
I can select items for purchase from a website.			



Job Shadowing: Auto Parts Sales Flyer

It was a quiet morning at Swift Auto Parts. Jerry was looking over the flyers and magazines that came from their suppliers. Randy had sent Jerry, Reg and Mark to an auto parts trade show. They had come back with piles of information about new suppliers and good deals on parts.

Randy said, “Since it’s not too busy this morning, would you mind doing the purchase orders?”

“Happy to,” said Jerry.

“I had a look through the new Ace catalogue and sale flyer,” said Randy. “I’d like to try out a few new items — plus they have a great deal on spray guns. Here — I’ve marked the quantities and the items I want.”

Jerry had a look at Randy's list. It was short, but Jerry wasn't surprised at that. As a small business owner, Randy had to be very careful with his cash flow. Nonetheless, Jerry was disappointed that he hadn't ordered one or two items that he thought would sell very well. He decided to talk to Randy about them.

"Randy, I've looked over your Ace order and notice that you haven't ordered the half ton engine stand. I've had a few requests for them from customers, and right now Ace is offering 25% off. It seems like a good time to see whether or not we should stock them."

Randy took the sale flyer from Jerry. "That is a good price," he agreed. "You're right, it isn't much of an investment at 80 bucks. Order two and we'll see what happens."

Jerry was pleased. He felt that Randy respected his opinion and experience. Randy was pleased too. His parts business was growing, and he did not always have the time to go through catalogues and flyers as carefully as he used to.



JOB TASK ONE: Reading a Flyer

Jerry put the sales flyer beside the purchase order on the counter. He was ready to begin filling in the order.



What information does Jerry need before filling in the items on the purchase order?

- 1 Locate and list four pieces of information Jerry should keep in mind when he is ordering. Refer to the sales flyer on the next page.

ACE Auto Parts

Trade Show Blow Out!

25% Off!!

1,000 lb. Engine
Stand



\$78.50

Block Heater Cord



\$6.99

3 pc hvlp Spray Gun Kit



\$17.50

Booster
Cables



\$34.99

2 pc Tarp Set



\$11.99

20 Foot Tow Rope



\$12.99

When ordering refer to Catalogue for part numbers.

All Prices in Effect Until July 15th. We Will Match All Our Competitors' Prices!

Workplace Know-How



If you are filling in a purchase order form or some other workplace document, you need to pay attention to detail.

- Follow the instructions. Make sure you fill in each section.
- Include
 - ✓ The date
 - ✓ Correct contact information
 - ✓ Correct shipping address and billing address — they are not always the same.
 - ✓ Correct quantity, price and item number
- Make sure you keep a copy for your records.



Why is it a good idea to keep a copy of your purchase order?



JOB TASK TWO: Using a Purchase Order

Jerry carefully filled in the purchase order with the item number and quantity for each part. He looked over the order to make sure he had included all the necessary information.



What special instructions are included on the purchase order for the supplier?



What do you think “authorized” means on the purchase order? Why do you think orders have to be authorized?

Jerry took the completed purchase order to Randy to initial it and then faxed it to the supplier.

Swift Auto Parts

PURCHASE ORDER

Swift Auto Parts
39 Cordova Ave.
City, ON L0J 1E0

DATE: JUNE 16, 20__
P.O. # 1217

VENDOR: Ace Auto Parts Supply
143 Industry Circle
Hamilton, ON L8Z 2F2
905 223-8875

SHIP TO: Swift Auto Parts
39 Cordova Ave.
City, ON L0J 1E0
905 832-2415
Customer ID SAP4474

SHIPPING METHOD	SHIPPING TERMS	DELIVERY DATE
Purolator	C.O.D.	June 19, 20__

QTY	ITEM #	DESCRIPTION	UNIT PRICE	LINE TOTAL
2	291932-2	½" Scale Torque Wrench	14.37	28.74
6	715651-1	10A Battery Charger	27.32	163.92
6	824887-1	Electric Paint Spray Gun	17.50	105.00
3	209004-2	2 Ton Jack Stands	14.39	43.17
2	500384-2	1000 lb. Folding Engine Stand	78.50	157.00

1. Please send two copies of your invoice.
2. Enter this order in accordance with the prices, terms, delivery method, and specifications listed above.
3. Please notify us immediately if you are unable to ship as specified.
4. Send all correspondence to:

Randy Spenser
Swift Auto Parts
39 Cordova Ave.
City, ON L0J 1E0

Authorized by: RS

Date: 16 Jun 20--



JOB TASK THREE: Checking the Order

A few days later the order from Ace Auto Parts arrived. Jerry started to unpack and shelve it.

“Make sure you check the packing slip with the shipment and the purchase order,” said Randy.



Why do you think Jerry should compare the shipment with the packing slip and the purchase order?

- 1 Compare the packing slip on the next page with the purchase order. Is the shipment correct? Put check marks beside each item if it is correct. Circle any items that are not correct.
- 2 Did you find any errors? List them below.



What do you think Jerry should do about the errors on the purchase order?

***** Packing Slip *****

17 June 20--

Ace Auto Parts Supply
143 Industry Circle
Hamilton, ON L8Z 2F2

Ship to:

Swift Auto Parts
39 Cordova Ave.
City, ON L0J 1E0

Cust. no. 453706

2	291932-2	½" Scale Torque Wrench	14.37
6	715651-1	10A Battery Charger	27.32
6	824887-1	Electric Paint Spray Gun	21.50
B/O	209004-2	2 Ton Jack Stands	14.39
1	500394-1	1 Ton Transmission Jack	299.50

JL

**OVERTIME ACTIVITY: Filling in a Purchase Order**

- 1 Go to the **Princess Auto** website: www.princessauto.com/currentsale/items to check out their sale items.
 - ▶ Choose an item to order.
 - ▶ Click on the item and fill in all the information on the blank purchase order on the next page.
 - ▶ Repeat this for a total of six items.
- 2 Fill in all the shipping information on the purchase order. Use Swift Auto Parts as the purchaser.
- 3 When you have completed the purchase order, have your instructor “authorize” it.

Performance Review

In this chapter you have worked on essential document use skills for work. How do you think you did? Use the chart below to reflect on your improved ability to use documents for work.

Essential Skill	Exceeds Expectations	Meets Expectations	Needs Additional Training	LBS	ES
Document Use					
I can use a document such as a sales flyer.				1	1
I can enter information into a purchase order.				1	1
I can search for information online and enter that information into a form.					2
I can use two different documents to compare similar information.				2	2
Other Essential Skills					
Thinking					
I can find and apply necessary information to complete a work task.					2

CHAPTER 4

Keith Uses Documents

Rate yourself on the skills employers want.

Employability Skills	I have this skill.	I am not sure.	I need to work on this skill.
I can read and understand workplace notices.			
I can read and understand workplace safety information.			
I can read and understand a pay cheque and pay stub.			
I can read and understand a timesheet.			
I know how to find important information in a document.			



Job Shadowing:

Keith was looking at the small notice board that hung in the trailer. Ever since he missed a safety meeting, he had gotten into the habit of looking at it every day. Now he noticed a hand written sign announcing a toolbox meeting.

Toolbox Meeting

Date: Monday, January 25, 2010

Time: 7 am

Location: Main Office Boardroom

Agenda

1. Health Hazards of Asbestos
2. Other safety issues and suggestions by work crews

Attendance is mandatory for all residential and industrial job site workers.

“A toolbox meeting,” Keith read aloud.

“Yeah, you missed the last one,” said Pete, punching Keith in the arm.

“Ow! Hey, what’s a toolbox meeting?” Keith asked, rubbing his arm. One of the things that Keith really liked about Pete is that he never made you feel stupid, even if you worried that you were asking a stupid question.

“That’s just the name of the short safety meetings we have,” Pete explained.

Workplace Know-How



Workplaces normally have a bulletin board centrally located for all employees. You should check it for new information when you come in to work.

What kind of information will you find on the bulletin board?

- Announcements
- Changes in rules or regulations
- Staffing changes
- Safety information
- Meeting dates and times
- Upcoming events

In a large workplace the bulletin board is often the main communication method between management and employees.



What could happen if you don’t check the staff bulletin board every day?



JOB TASK ONE: Meeting Announcement

1 Look at the meeting announcement on page 149. List all the key pieces of information given in the announcement.

- a. _____
- b. _____
- c. _____
- d. _____
- e. _____



JOB TASK TWO: Toolbox Meeting Guide

Workplace Know-How



Construction companies often hold regular “Toolbox Meetings.” These are short meetings that can cover a variety of topics.

Accidents, near misses and other safety issues are frequently discussed to prevent further accidents. All employees must attend these meetings. Responsible employers encourage their employees to raise issues and ask questions.

Management is responsible for training their employees on safety procedures. They must document what training has been provided and to whom.

The Ministry of Labour is responsible for ensuring that workplaces are safe. When an accident occurs, the Ministry investigates. Safety procedures and employee training will be a part of that investigation.

For more information, check out the Ministry of Labour website for young and new workers at WorkSmart Ontario.

<http://www.worksmartontario.gov.on.ca/scripts/default.asp>

Look at the document on the next two pages and answer the following questions.

- 1 Are staff members encouraged to actively participate during the toolbox meetings? How do you know?



TOOLBOX MEETING GUIDE



Health hazards of asbestos

What is asbestos?

Asbestos is a strong, fire-resistant mineral fibre. In the past, asbestos was used for insulation against heat and noise, as well as for fire protection. Asbestos was also added to materials such as cement and plaster to give them more structural strength.

What are the hazards of asbestos?

Renovating or demolishing houses containing asbestos products can release asbestos fibres. These fibres are extremely fine and can stay in the air for hours.

Breathing in asbestos fibres may cause serious health problems, including lung disease and cancer.

Asbestosis is the name given to scarring and stiffening of the lungs caused by inhaling asbestos dust over many years. Asbestosis makes breathing difficult and may lead to fatal diseases such as pneumonia and heart disease.

Exposure to asbestos can also cause lung cancer and mesothelioma, a cancer of the linings of the lungs and abdomen.

Asbestos-related diseases usually develop many years after a person has been exposed to asbestos. The risk of developing these diseases increases with the amount of asbestos in the air you inhale and the length of time you are exposed. Smokers are at an increased risk.

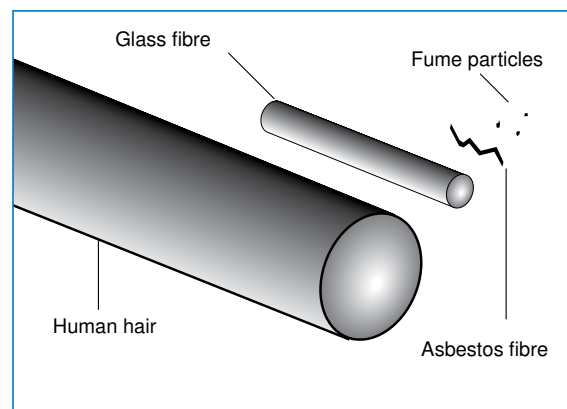

Asbestos fibres are extremely fine. The diagram above shows the relative sizes of a human hair, a glass fibre, an asbestos fibre, and fume particles.

Project: _____ Address: _____
 Employer: _____ Supervisor: _____
 Date: _____ Time: _____ Shift: _____
 Number in crew: _____ Number attending: _____

Other safety issues or suggestions made by crew members:

Record of those attending:

Name: (please print)	Signature:	Company:
1.		
2.		
3.		
4.		
5.		
6.		
7.		
8.		
9.		
10.		
11.		
12.		
13.		
14.		
15.		

Manager's remarks: _____

Manager: _____ Supervisor: _____
(signature) *(signature)*



WORKING TO MAKE A DIFFERENCE
worksafebc.com

- 2** Highlight the section in the document that Keith needs to fill in. Why do you think employees need to give this information? Explain why you think employers need this information.

- 3** Do you need to be worried about asbestos if you are building a new home? Why or why not?



JOB TASK THREE: Reading a Pay Cheque

- 1 Look at the cheque stub on the previous page.
 - ▶ Highlight the cheque amount on the cheque stub.
 - ▶ Can you find the total amount of deductions? Highlight that amount on the cheque stub.
 - ▶ Can you find the total amount before deductions? Highlight that amount.
- 2 What other deduction does Keith have on his pay cheque? Highlight that as well.
- 3 Highlight the total hours Keith worked.
- 4 What is his hourly rate? _____

Workplace Know-How



When you receive a pay cheque, you also receive a cheque stub which lists all your earnings and deductions. Always read it carefully and keep it in a safe place.

Employers keep back deductions that go to Revenue Canada. These include Canada Pension Plan (CPP), Employment Insurance (EI) and tax. This money is **withheld** and sent to Revenue Canada every month.

Keith was puzzled. I'm sure I worked more hours than 44, he thought to himself. As the line shuffled forward, Keith thought about his hours. Keith had worked many jobs, and he had learned early on that employers can make mistakes when counting up hours and issuing cheques. He was sure that he had worked 48 hours and had only been paid for 44. Keith deposited his cheque, but he tucked the pay stub safely into his wallet. He would speak to Mario on Monday, and double-check his timesheet.

Workplace Know-How



Anyone can make a mistake on a pay cheque. It is up to you to keep track of your hours and ensure that you are paid for the correct amount of time.

Write down all the hours you work in each pay period; if your hours are entered on a timesheet, make sure you check it.

It is also a good idea to keep your pay cheque stubs. If you are laid off or change jobs, the employer must provide you with a Record of Employment (ROE). If you have all your pay stubs, you can make sure the ROE has no mistakes.

All your employers within the past year must also send you a T4, which will show your total earnings and deductions. You must send this in when you file your income tax. Having all your cheque stubs means you can check that your T4 is correct as well.

If a mistake is made on your pay cheque, your employer will likely adjust it on the next cheque or issue you a new cheque.

If a mistake is made on your ROE or T4, the employer must send in an amended form to the Canada Revenue Agency.

On Monday morning Keith arrived a few minutes early. He asked Mario if he could see last week's timesheet.

Keith added up the hours for the last week — 48! At first he felt angry. He wanted to know why Straight Path Construction had robbed him of 4 hours pay. Those extra hours would have been at time and a half too! Then Keith took a deep breath and reminded himself that anyone can make a mistake. He had been working for this company for a couple months now and had never had any problems. There was no reason to think that they were trying to cheat him.

“Hey, Mario, I’ve got a problem with my hours,” said Keith. Keith pulled out his pay stub and then pointed out his timesheet hours to Mario.

“Huh” Mario grunted as he examined the documents. “Looks like we short-changed you.

Sorry about that, pal. See this? I guess that the bookkeeper read these numbers as sevens instead of nines.”

Keith nodded. “No problem,” he said. He could see how Mario’s nine could be taken for a seven.

Did you know that full-time employees are entitled to overtime pay if they work more than 44 hours in a week?

Straight Path Construction — Employee Timesheet

Employee Name	Keith Jenkins	Year to Date Totals		
		Regular Hours	Overtime Hours	Total
Supervisor	Mario	336		
Job Site	Connaught	6		
		342		

July 2010

July	Week 1	Overtime	Week 2	Week 3	Overtime	Week 4	Overtime	Week 5	Overtime
Monday			9	10		8		10	
Tuesday			10	9		8		10	
Wednesday			8	10		8		9	
Thursday	8		7	12		8		10	
Friday	8		6	7		8		9	
Saturday									
Sunday									
Weekly Total	16		40	48	4	40		44	
Total Reg. Hrs.	184								
Total OT Hrs.	4								



JOB TASK FOUR: Reading a Timesheet

1 Why do you think the timesheet shows Keith working only two days in the first week of July?

2 Highlight the hours the bookkeeper read incorrectly.



OVERTIME ACTIVITY: Toolbox Meeting Guide — Noise — how loud is it?

By now you are probably starting to realize that it is not always necessary to read everything in a document. Being able to find the information you want quickly is an important Document Use skill. Using the document on the next page, see how quickly you can find information. Remember to look at titles, bolded information and graphics. These will point you toward important information.

1 What is the document about?

2 What is its central message?

3 Which construction job has the most exposure to noise?

4 Which HPD should you use when you are exposed to less than 110 dBA?



Do you know of anyone who has hearing loss as a result of their job? What other occupations besides construction require workers to use hearing protection devices?

You can also suffer hearing loss outside of work. Can you think of ways this could happen?



TOOLBOX MEETING GUIDE



Noise—how loud is it?

This guide lists average noise exposure levels for various construction jobs and lists recommended hearing protection devices for those exposure levels. **Note:** An individual worker’s exposures may vary from these exposures.

Noise-induced hearing loss results from a combination of high sound levels and extended periods of exposure to sounds above 85 dBA.

Protect your hearing when performing these jobs.

Noise exposure levels

These are all eight-hour (or equivalent) exposures.

Construction job	Noise level (dBA)
Carpenter, Framers	91
Concrete worker	92
Crane operator	90
Drywaller	89
Electrician	89
Ironworker	93
Jackhammer operator	97
Labourer	93
Mobile equipment operator	91
Roofer	88
Truck driver	88
Welder	92

Hearing protection devices (HPD)

Hearing protection should be selected based on

- Noise exposure
- Communication demands
- Hearing ability
- Use of personal protective devices
- Temperature and climate
- Physical characteristics of the job or worker

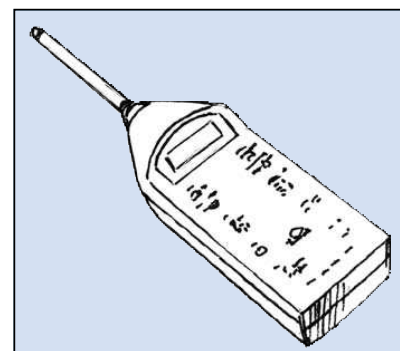

An integrating sound level meter averages noise levels over time.

Recommended HPD for various noise levels

Noise level	Recommended HPD
Less than 90 dBA	Class C, Grade 1
Less than 95 dBA	Class B, Grade 2
Less than 100 dBA	Class A, Grade 3
Less than 110 dBA	Earplugs + earmuffs

Project: _____ Address: _____

Employer: _____ Supervisor: _____

Date: _____ Time: _____ Shift: _____

Number in crew: _____ Number attending: _____

Other safety issues or suggestions made by crew members:

Record of those attending:

Name: (please print)	Signature:	Company:
1.		
2.		
3.		
4.		
5.		
6.		
7.		
8.		
9.		
10.		
11.		
12.		
13.		
14.		
15.		

Manager's remarks: _____

Manager: _____ Supervisor: _____

(signature)

(signature)



WORKING TO MAKE A DIFFERENCE
worksafebc.com

Performance Review

In this chapter you have worked on essential document use skills for work. How well do you think you did? Use the chart below to reflect on your improved ability to use documents for work.

Essential Skill	Exceeds Expectations	Meets Expectations	Needs Additional Training	LBS	ES
Document Use					
I can locate information on a sign-in sheet.				1	1
I can locate information on a pay cheque/pay stub.				1	1
I can locate information on a timesheet.				1	1
Other Essential Skills					
Reading					
I can read and understand safety information.				2/3	2
Thinking Skills					
I can make reasonable assumptions when information is unavailable.					2

EmployAbility SUCCESS!

MODULE 3

Ready to Use Math at Work



CHAPTER	TITLE	PAGE
–	Practitioner Guidelines	166
–	Student Guidelines	181
1	Erica Uses Math	183
2	Jerry Uses Math	197
3	Maria Uses Math	207
4	Keith Uses Math	221

Practitioner Guidelines and Answer Key

Overview of Module Three — Numeracy

There are four chapters in this module.

Chapter One focuses on recipe measurement and money handling skills with Erica. The skills addressed are:

- ▶ Doubling and tripling a recipe
- ▶ Making and counting back change
- ▶ Balancing the daily cash

Chapter Two begins with Jerry and focuses on money calculations. The numeracy tasks that he tackles are:

- ▶ Adding up invoices
- ▶ Calculating sales tax

Chapter Three provides Maria with the opportunity to use estimation and time management skills. Maria will work on:

- ▶ Scheduling appointments
- ▶ Estimating time required for client visits and travel to and from her appointments

Chapter Four provides Keith with the opportunity to improve his measurement skills. The tasks he encounters are:

- ▶ Simple ratios involving doubling and tripling amounts
- ▶ Measuring in feet and inches
- ▶ Calculating the area of a simple rectangle
- ▶ Calculating the square footage of a room
- ▶ Measuring, using a scale drawing

Chapter-Specific Instructions and Answer Key

CHAPTER ONE: Erica Uses Math

This chapter includes the skills needed for doubling recipes. Students ought to be able to add simple fractions. It would be helpful to have on hand a set of measuring spoons and cups for this chapter. You may need to review recipe-specific vocabulary as it arises.

The second part of this chapter involves making change, including counting it back. It would be helpful to have some coins and bills for students to practice with. The website www.funbrain.com/cashreg/index.html provides the opportunity for practice as well.

The final two activities in this chapter involve adding up money. You may wish to review with students how to add up coins and bills, using decimals.



Do you have any tips for Erica?

Some students may have experience with doubling recipes, and they may provide suggestions on how to tackle this. There may also be some students who do not know how to measure volume. Students might suggest writing beside the original recipe so that they will only have to calculate the doubled recipe once.



JOB TASK ONE: Doubling a Recipe

The filled in chart should be as follows:

Ingredient	Single Amount	Doubled
Raisins	1 cup	2 cups
Warm water	2 cups	4 cups
Flour	2 cups	4 cups
Baking powder	1 tablespoon	2 tablespoons
Baking soda	2 teaspoons	4 teaspoons
Salt	1 teaspoon	2 teaspoons
Cinnamon	1 teaspoon	2 teaspoons
Eggs	3	6
Vegetable oil	1 cup	2 cups
Brown sugar	$\frac{3}{4}$ cup	$1\frac{1}{2}$ cups
Carrots	3 cups	6 cups
Walnuts	$\frac{2}{3}$ cup	$1\frac{1}{3}$ cups

1

Workplace Know-How



This section provides an opportunity to discuss the importance of counting the change back. Counting it back prevents giving too little or too much change back because it is easy to pick up too few or too many bills.

You may also want to discuss the reasons why few cashiers count back the change. (time, reliance on the cash register...)



Job Shadowing Part Two: Making Change

Answers may vary when counting back change as there may be several combinations. The general rule is start with the smallest denominations first. Start with the cost of the item and count up to the amount the customer gave the cashier.

- 1 a) \$4.01
- b) Answers may vary slightly but she should receive one penny and two toonies or a combination of loonies and toonies.
- c) \$6.00, (one penny), \$8.00, \$10.00 (2 toonies)

- 2 a) \$14.00
b) She must count from \$26.07 to \$40.07, 28.07, 30.07, 40.07
- 3 a) Total purchase = \$5.07, \$15.00
b) Answers may vary but if you give the customer a five and a ten, you would count back \$10.07, \$20.07.
- 4 a) \$13.84
b) \$6.16
c) \$13.85, \$13.90, \$14.00, \$15.00, \$20.00



JOB TASK THREE: Balancing the Cash

The completed cash report is provided below. Prior to doing this activity, you may wish to demonstrate to students how to add up coins and bills using decimals. Most students will be able to add up their own money; they will also need to know how to write the coin and bill amounts correctly in order to add them up on paper with a decimal point.

Daily Cash Total		
Coin on hand		Totals
27	Pennies	.27
19	Nickels	.95
34	Dimes	3.40
17	Quarters	4.25
21	Loonies	21.00
18	Toonies	36.00
Total in coins		65.87
Bills on hand		
12	× \$5	60.00
7	× \$10	70.00
24	× \$20	480.00
	×	
Total in Bills		610.00
Total Cash		675.87



JOB TASK FOUR: Balancing the Receipts (Cash, Debit and Credit Cards)

Debit Purchases	\$475.73
Visa/Mastercard Purchases	\$91.76
Cash	\$675.87
Total Sales	\$1243.36
Starting Cash on Hand (subtract this amount)	\$120.00
Total	\$1123.36



OVERTIME ACTIVITY: Tripling a Recipe

- 6 cups of flour
- 3 tablespoons of baking powder
- 1½ teaspoons of salt
- 6 tablespoons of sugar
- 15 tablespoons of butter or ¾ cup plus 3 tablespoons
- 3 cups heavy cream
- 3 cups fresh blueberries
- 1½ cups lemon juice
- 6 cups sugar
- Zest of three lemons
- 3 tablespoons butter

CHAPTER TWO: Jerry Uses Math



JOB TASK ONE: Costing Repair Kits

- 1 \$1360.00
- 2 \$1112.00
- 3 \$26.56
- 4 $\$34.75 - \$26.56 = \$8.19$
- 5 \$262.08



JOB TASK TWO: Totaling an Invoice

- 1 $118 + 1360 = \$1478.00$
- 2 \$1360.00
- 3 $32 \times 34.75 = \$1112.00$



JOB TASK THREE: Calculating Sales Tax

- 1 $1112 \times 1.13 = \$1256.56$
- 2 $1256.56 - 850.00 = 406.56$



OVERTIME ACTIVITY: Completing Invoices

The completed invoices should look as follows:

Quantity	Description	Unit Price	Total
4	Passenger Side Mirror Part # FD56ER	35.61	142.44
12	Nifty XTREME floor mats, set of 2, black	75.73	908.76
		Sub-Total	1051.20
		Sales Tax	136.66
		Shipping & Handling	10.00
		Total Due	1197.86

Quantity	Description	Unit Price	Total
6	Bulldog Remote Starter LS2000	126.80	760.80
9	Covercraft Bench Seat Pet Pad, Grey	52.14	469.26
3	Universal Pet Barrier, Black, 45" H x 65" W adjustable	80.38	241.14
		Sub-Total	1471.20
		Sales Tax	191.26
		Shipping & Handling	10.00
		Total Due	1672.46

CHAPTER THREE: Maria Uses Math

This chapter includes time management and scheduling tasks.

The second part of the chapter involves keeping track of mileage and gas expenditures.

**JOB TASK ONE: Estimating Time**

- 1 It would take about 20 minutes (or 25 if the traffic was bad) to drive to 41 Tulip Court. That would get her there at about **8:05**. On time? ___ Late? ✓
- 2 Maria would spend about 45 minutes with Doris. She would be finished at about **8:50**. On time? ___ Late? ✓
- 3 It would take 15 minutes to get to Redburn from there. She would probably spend at least 50 minutes with Bob. He so rarely received any visitors, Maria always tried to spend a few extra minutes with him. She would be finished at Bob's around **9:55**. On time? ___ Late? ✓
- 4 It would take Maria another 15 minutes to drive to Mill Road. She planned to spend 45 minutes with Freda. Maria would leave Freda's around **10:55**. On time? ___ Late? ✓
- 5 Maria needed just 10 minutes to drive home to pick up Sophia and then another 10 to get to the dentist. Just in case they had to wait, Maria planned for an hour at the dentist and another 10 minutes to drive home. If the appointment actually took 50 minutes, she would arrive back home at about **12:15**.
- 6 After her busy morning, Maria decided that she would relax at home and take a full hour for lunch. Does she have time for a full hour before her next appointment? No How much time does she have for lunch? **45 minutes**
- 7 Fortunately, Eva's house on James Street was not far from Maria's place, and she could be there in about 5 minutes or at **1:05**. On time? ___ Late? ✓
- 8 Rose Heights Avenue North would be about a 20-minute drive. In order to arrive there at 2 pm, Maria needed to leave Eva Tomasso's home at **1:40**.
- 9 A first visit often took at least an hour. If she took an hour and ten minutes with Mrs. Mallory and needed 15 minutes to drive back to Tulip Court, when would Maria see her client, Bruno? **3:25** On time? ___ Late? ✓



JOB TASK TWO: Time Management

- 1 Answers may vary somewhat but students should state that Maria will be late for her appointments because she has not allowed enough travel time. She did not leave early enough for her first appointment.
- 2 7:30 or earlier would be the ideal time to leave.
- 3 No, she will be about 15 minutes late.
- 4 No, she will be at least 25 minutes late.



JOB TASK THREE: Scheduling

This is a challenging activity and answers may differ. It is easier to accomplish if the day planner, the notes and travelling times are together while doing the task. Students should try to leave a little extra time for contingencies. The planner page on the next page shows the revised appointment schedule.



JOB TASK FOUR: Adding up Expenses

\$177.41

Tuesday 20 June	
7:00 AM	
7:15	Doris Langly, 1035 — 41 Tulip Court
7:30	
7:45	
8:00 AM	
8:15	
8:30	Bob Hines, 44 Redburn Street
8:45	
9:00 AM	
9:15	
9:30	
9:45	Freda Gregson, 25 Mill Road
10:00 AM	
10:15	
10:30	
10:45	
11:00 AM	Dentist with Sophia
11:15	
11:30	
11:45	
12:00 PM	
12:15	
12:30	
12:45	Eva Tomasso, 87 James Street
1:00 PM	
1:15	
1:30	
1:45	
2:00 PM	Mrs. Mallory, 29 Rose Heights Ave N
2:15	
2:30	
2:45	
3:00 PM	
3:15	
3:30	Bruno Gentile, 1204 — 41 Tulip Court
3:45	
4:00 PM	
4:15	
4:30	
4:45	
5:00 PM	

She will finish with Bruno around 4:15. She will arrive home around 4:45.



JOB TASK FIVE: Calculating Mileage

The completed chart should look like the one below:

Date	Odometer Reading		Kilometres Travelled	Details (Client ID)	Total Mileage over 20 kms.
	Beginning	Ending			
May 3	89,323	89,371	48	0321, 0098, 0105, 0210, 1034, 0658	28
May 4	89,380	89,420	40	0086, 1090, 0495, 0023	20
May 5	89,431	89,475	44	0625, 0083, 0591, 1008	24
May 6	89,491	89,531	40	0086, 1090, 0495, 0023	20
May 7	89,542	89,590	48	0321, 0098, 0105, 0210, 1034, 0658	28
May 10	89,622	89,670	48	0321, 0098, 0105, 0210, 1034, 0658	28
May 11	89,681	89,721	40	0086, 1090, 0495, 0023	20
May 12	89,734	89,782	44	0625, 0083, 0591, 100	24
May 13	89,793	89,854	40	0086, 1090, 0495, 0023	20
May 14	89,863	89,911	48	0321, 0098, 0105, 0210, 1034, 0658	28
May 17	89,936	89,984	48	0321, 0098, 0105, 0210, 1034, 0658	28
May 18	89,992	90,032	40	0086, 1090, 0495, 0023	20
May 19	90,038	90,082	44	0625, 0083, 0591, 1008	24
May 20	90,089	90,129	40	0086, 1090, 0495, 0023	20
May 21	90,138	90,186	48	0321, 0098, 0105, 0210, 1034, 0658	28
May 25	90,234	90,290	56	0086, 1090, 0495, 0023, 0321, 0098,	36
May 26	90,298	90,345	47	0625, 0083, 0591, 1008 0105, 0210,	27
May 27	90,362	90,411	49	0086, 1090, 0495, 0023 1034, 0658	29
May 28	90,422	90,470	48	0321, 0098, 0105, 0210, 1034, 0658	28
Total Kilometres			860	Total Allowed Mileage	480
Reimbursement Amount (at .40/km)					\$192.00

**OVERTIME ACTIVITY: Learning about Time Management**

These activities provide the opportunity for students to discuss and assess their own time management skills. They can take the assessment and/or read about some time management tips.

www.mindtools.com/pages/article/newHTE_88.htm

www.timemanagementhelp.com/tips.htm

CHAPTER FOUR: Keith Uses Math

The emphasis in this chapter is on measurement, critically important for anyone wishing to work in the construction sector. Note that the construction sector, particularly carpentry and plumbing, continues to use imperial measurement.

Students need to be able to read a ruler/measuring tape. The measurements in this chapter do not require anything less than $\frac{1}{4}$ inch. On the job, however, measurements must be accurate to one 16th of an inch.



JOB TASK ONE: Mixing Concrete

The completed chart should look like the one below:

Cement	Sand	Gravel
1	2	3
6	12	18
9	18	27
4	8	12
3	6	9



Job Shadowing Part Two: Measuring



How many sheets of plywood do they need for the roof?

The correct answer is 14.



JOB TASK TWO: Roofing Measurement

- 1 25 sheets of plywood
- 2 70 sheets of plywood
- 3 96 sheets of plywood
- 4 42 sheets for the house and 18 sheets for the garage

Workplace Know-How



This provides an opportunity for discussion about training which would improve their ability to gain employment in the construction sector.

Employers value workers who have WHMIS, Fall Arrest, first aid, etc., which indicate an awareness of the importance of working safely.

Metric and Imperial Measurement



There are no specific activities requiring metric and imperial conversion.

Entry-level construction workers/helpers would not be required to do this.

Carpenters and foremen would be responsible for conversion for the building code and would use a calculator with this function. The website provided in this section also converts any measurement.



OVERTIME ACTIVITY: Measuring Area

- 1
 - a) 200 square feet
 - b) 20 square feet
 - c) 180 square feet
 - d) 20 square feet

- 2 **Paint Coverage**
 - a) 68 feet
 - b) 544 square feet
 - c) 474 square feet
 - d) 1.35 or 1.4
 - e) One gallon

Module 3 — Student Guidelines

Ready to Use Math at Work

All jobs require some math skills. You may be responsible for using a cash drawer, for measuring lengths of fabric or wood, or even for adding up the number of toppings that go onto a pizza. Math, or numeracy as it is sometimes called, is an Essential Skill, and like the other Essential Skills you have practiced so far, numeracy is transferable from job to job. When you practice the activities in this module, you will be improving your numeracy for whichever job you wish to apply for.

While this module focuses on numeracy, you will also be practicing other Essential Skills. When you are on the job, you are often required to perform a number of skills when you are given a specific task.

- ▶ Jerry will be calculating discounts and the cost of a shipment of repair kits.

- ▶ Erica will be doubling a muffin recipe and learning how to count back change to customers. She will also learn how to count her cash drawer so that the money is ready to be deposited at the bank.
- ▶ Maria learns to manage her time more effectively. She also has to decide whether or not she is losing money in mileage and gas costs as she drives around the city to see her clients.
- ▶ Keith learns about ratios through mixing cement. He also uses diagrams to help him decide how many sheets of plywood he needs to replace on a roof.

Are you ready for numeracy at work? Read the scenarios and do the activities that follow. They will help you to improve your numeracy skills for the job you want.

CHAPTER 1

Erica Uses Math

Do you have the skills necessary to do math at work?

Employability Skills	I have this skill.	I am not sure.	I need to work on this skill.
I can double and triple a recipe.			
I know how to make change.			
I know how to count back the correct change.			
I know how to balance my cash.			

Part One



Job Shadowing: Doubling a Recipe

One of Erica’s favourite jobs at Dough Dude Bakery is making muffins. She arrives before the bakery-deli opens in the morning and makes several batches. Erica is proud of the fact that the muffins are very popular in both the bakery and the deli. Many customers buy a coffee and a muffin, or they will buy a half dozen muffins to take home.

Erica bakes at least four varieties of muffins each day. The raisin bran are especially popular, and Erica has noticed that they have sold out before lunchtime whenever she has made them.

Erica mentioned this to Sam as she was washing her hands.

“Try doubling the recipe,” said Sam.

“Okay,” said Erica. She had never doubled a recipe before.



Do you have any tips for Erica?

Erica got out large bowls and put them on the baking table. Then she looked at the recipe.

“Let’s see...” she murmured to herself. “3 cups of bran doubled...that’s 3+3, which is six.” Erica measured six cups of bran into a bowl.

“Now I need to add the buttermilk. 2+2 cups is four cups of buttermilk. Hey, this is easy!” Erica said to herself.

Erica set aside the bran and buttermilk and scanned the rest of the recipe. Oh no — fractions! How could she double the oil and the brown sugar?

Here is Dough Dude’s bran muffin recipe. Help Erica double the recipe.

Raisin Bran Muffins

Ingredients

- 3 cups wheat bran
- 2 cups buttermilk
- $\frac{2}{3}$ cup vegetable oil
- 2 eggs
- $1\frac{1}{2}$ cups brown sugar
- 1 teaspoon vanilla extract
- 2 cups all-purpose flour
- 2 teaspoons baking soda
- 2 teaspoons baking powder
- 1 teaspoon salt
- 1 cup raisins



Method

- 1 Preheat oven to 375 degrees F (190 degrees C). Grease 24 muffin cups or line with paper muffin liners.
- 2 Mix together wheat bran and buttermilk; let stand for 10 minutes.
- 3 Beat together oil, egg, sugar and vanilla and add to buttermilk/bran mixture. Sift together flour, baking soda, baking powder and salt. Stir flour mixture into buttermilk mixture, until just blended. Fold in raisins and spoon batter into prepared muffin tins.
- 4 Bake for 15 to 20 minutes, or until a toothpick inserted into the centre of a muffin comes out clean.

Erica remembered that as long as two fractions have the same denominator (bottom number), they can be added together.

Vegetable oil

$$\frac{2}{3} + \frac{2}{3} = \frac{4}{3} \text{ or } 1\frac{1}{3}$$

Erica also remembered that she could add whole numbers together first and then add the fractions.

Brown sugar

$$1\frac{1}{2} + 1\frac{1}{2} = 2\frac{2}{2} \text{ or } 3.$$

“Okay! I need one and one third cups of oil and 3 cups of brown sugar,” said Erica.

When Erica put the muffins in the oven, she decided it would be a good idea to write out the doubled recipe beside the original.



JOB TASK ONE: Doubling a Recipe

Dough Dude’s carrot muffins are also very popular. Double the recipe for Erica.

Carrot Muffins

Ingredients

- 1 cup raisins
- 2 cups warm water
- 2 cups all-purpose flour
- 1 tablespoon baking powder
- 2 teaspoons baking soda
- 1 teaspoon salt
- 1 teaspoon ground cinnamon
- 3 eggs
- 1 cup vegetable oil
- $\frac{3}{4}$ cup brown sugar
- 3 cups shredded carrots
- $\frac{2}{3}$ cup walnuts



Use the space provided on the following chart for your calculations.

Ingredient	Single Amount	Doubled
Raisins		
Warm water		
Flour		
Baking powder		
Baking soda		
Salt		
Cinnamon		
Eggs		
Vegetable oil		
Brown sugar		
Carrots		
Walnuts		



Has it been a while since you last worked with fractions? Here are a couple of websites to refresh your memory:

www.mathsisfun.com/fractions_addition.html

This site covers the basics on how to add fractions.

www.coolmath4kids.com/fractions/index.html

The Cool Math website includes more lessons on fractions. You can begin with the very basics and work at your own pace.

Part Two



Job Shadowing: Making Change

Erica has been using the cash registers at Dough Dude Bakery and Deli for many months now. She is comfortable with doing regular transactions involving cash, credit cards and debit cards.

The one thing Erica has never learned to do is to count back the change to customers. She always gives them the correct amount of change because the cash register tells her how much to give. But sometimes, customers change the amount that they give Erica after she has keyed in the number in the till. At this point, Erica always calls for help.

Erica took the \$20 bill from her customer for an order of bread totalling \$12.56. She keyed \$20.00 into the till which showed that she owed the customer \$7.44 in change.

“Wait!” said her customer. “I don’t want all of that loose change. Here, let me give you \$2.56.”

“I’ve already keyed in the \$20,” said Erica politely. “Do you mind if I just give you the change?”

“Yes, I mind. My purse weighs a ton already. Just take this change and give me the ten dollars.”

“Ten dollars? Now I’m confused. Edna!” Erica called.

Edna came bustling over to the till. She looked at the bill and the money the customer was trying to give Erica.

“Just take the change and give the lady ten dollars,” she said.

After the customer had left, Erica apologized.

“Sorry, Edna. I’m fine with the cash as long as I can just do what the register tells me to do! I’m not very good when I have to work things out myself.”

“Making change is a very useful skill. What would you do if we had a power outage and had to make sales without the register? Also, I think it is time that you learn how to make change when the customer changes her mind about what money she gives you.”

“I think so too, Edna. But how do I learn?” said Erica.

How to Make Change

Making change is easier if you always remember this rule:

Begin with the total of the sale and count until you reach the amount paid.

Let's use Erica's sale as an example. The sale totalled \$12.56 and the customer first gave her \$20, which Erica entered into the register. The register tells Erica that she owes the customer \$7.44, which she takes out of the cash drawer.

Begin with the total of sale: \$12.56

Count until you reach the amount paid by customer: \$20.00

Erica needs to count from \$12.56.

She will have coins and a bill to give the customer. She needs to count back the coins first. Here is how.

- 1 Say the amount of the sale: "12.56"
- 2 Add the loose change: "Plus four pennies makes 12.60, plus a nickel makes 12.65, plus a dime makes 12.75, plus a quarter makes 13.00, plus two loonies makes 15.00."
- 3 Add the bill: "Plus 5 makes 20."

Erica would count back like this: 12.56, 12.60, 12.65, 12.75, 13, 15 and 5 makes 20. After she got used to counting back change, she could give the customer all of the coins together and say,

"12.56 plus 2.44 is 15 and 5 makes \$20." The important thing for Erica and all cashiers to remember is to count back from the smallest coins to the largest bills.

Erica became confused when the customer handed her an extra \$2.56 in change.

What should she have done?

The sale totalled \$12.56.

The customer gave Erica \$20 plus \$2.56 or \$22.56.

Erica needs to count from \$12.56 to \$22.56. How much change should she give the customer?

Making change becomes easier with practice. Go to the website below and then click on the Canadian flag to practice making change with Canadian currency.

www.funbrain.com/cashreg/index.html

Workplace Know-How



It is true that new cash registers make a cashier's job easier. You enter the amount the customer gives you and it tells you the amount of change to give back. This makes it easier to ensure that the cash balances with the total sales at the end of the shift. A cashier who does not balance all the time will likely lose their job.

Many cashiers put the money given to them by the customer on top of the cash drawer while they make the change. This ensures that they count back up to the right amount. If the customer is confused and says, "Hey, I gave you a twenty dollar bill, not a ten!", then the cashier can politely point to the ten dollar bill lying on top of the cash drawer.



JOB TASK TWO: Making Change

Help Erica make change for her customers. First, write the total amount of change, showing which coins and bills a customer would receive. Next, show how Erica would count it back. You can do the second part out loud with your instructor or colleague if you like.

- 1 a) A customer purchases six muffins for \$5.99. She hands Erica a \$10 bill. What is her change?

- b) What coins and/or bills will she receive?

- c) How will Erica count it back? Remember to start with the smallest coin first.

- 2 a) A customer's purchase comes to a total of \$26.07. Erica receives two twenties and seven pennies. What should the customer receive back in change?

- b) How will Erica count the change back?

- 3 a) A customer purchased three muffins and two coffees. Her bill came to \$5.07. She gave Erica a \$20 bill, one nickel and two pennies. How much change should the customer get back?

- b) How will Erica count back the change?

- 4 Two customers came into Dough Dude Bakery and Deli together. The first customer's order came to \$6.59. The second customer said he would pay for both of them. His order came to \$7.25. He gave Erica a \$20.

- a) What is their total purchase?

b) How much change should Erica give him?

c) How will Erica count back the change?

At the end of the week, Edna said to Erica, “You have done such a good job learning how to count back change to customers, I think you are ready to learn some more money math. It is time you learned how to balance your cash. If you can do this, it will save me time preparing the bank deposit every night.”

If I can learn how to count back change, I am sure I can learn this as well, thought Erica.

“What do I do first?” asked Erica.

“First total your cash, cheques, credit card and debit purchases separately,” said Edna.

“Next, subtract the amount of cash on hand at the beginning of your shift. The amount is the same every day. We always leave \$120.00 in the register,” said Edna.

“The total should equal your total sales for the day. Your number should be the same as the cash register sales report.”

Erica gathered all the debit purchases first. They totalled \$475.73. Credit card purchases came to \$91.76. Next Erica added up the cash.



JOB TASK THREE: Total the cash in the register.

You can use a calculator for this activity. Remember to write the amounts, using a decimal point.

Daily Cash Total		
Coin on hand		Totals
27	Pennies	$27 \times .01 = .27$
19	Nickels	$19 \times .05 =$
34	Dimes	$34 \times .10 =$
17	Quarters	
21	Loonies	
18	Toonies	
Total in coins		
Bills on hand		
12	$\times \$5$	
7	$\times \$10$	
24	$\times \$20$	
	\times	
Total in Bills		
Total Cash		



**JOB TASK FOUR:
Balancing the Receipts (Cash, Debit and Credit Cards)**

Help Erica balance her cash. Add up all the receipts and subtract the cash on hand.

Cash Report

Date: May 3, 20__ Cashier: Erica

Debit Purchases	
Visa/Mastercard Purchases	
Cash	
Total Sales	
Starting Cash on Hand (subtract this amount)	
Total	

When Erica was done, she gave the cash report to Edna.

“Great job! You aren’t even out by one cent,” said Edna.

“It wasn’t as bad as I thought it would be. I just took my time and checked everything twice,” replied Erica.

Workplace Know-How



In most retail businesses, the manager or owner is responsible for preparing the nightly bank deposits. Cashiers are often responsible for balancing their own cash. Usually a simple report is filled in and the cash sales tape is attached to it.

It is a good idea to check that the cash on hand (sometimes called float) is the correct amount before starting your shift.

**OVERTIME ACTIVITY: Tripling a Recipe**

- 1 Using the recipe below, increase the ingredient amounts to make a **triple** batch of blueberry scones.

Blueberry Scones with Lemon Glaze

Ingredients

Blueberry Scones:

- 2 cups all-purpose flour
- 1 tablespoon baking powder
- ½ teaspoon salt
- 2 tablespoons sugar
- 5 tablespoons unsalted butter, cold, cut in chunks
- 1 cup heavy cream, plus more for brushing the scones
- 1 cup fresh blueberries

Lemon Glaze:

- ½ cup freshly squeezed lemon juice
- 2 cups confectioners' sugar, sifted
- 1 lemon, zest finely grated
- 1 tablespoon unsalted butter



Performance Review

In this chapter you have worked on the numeracy skills necessary for work. How do you think you did? Use the chart below to reflect on your improved ability to use numeracy skills for work.

Essential Skill	Exceeds Expectations	Meets Expectations	Needs Additional Training	LBS	ES
Numeracy					
Money Math					
I can count back correct change from a purchase.				3	1
I can add up receipts.				3	1
I can subtract cash on hand.				3	1
Measurement					
I can double or triple a recipe.				2/3	2
Number Concepts					
I can add and subtract decimals.				3	1
I can add simple fractions.				2/3	1

CHAPTER 2

Jerry Uses Math

Do you have the skills necessary to do math at work?

Employability Skills	I have this skill.	I am not sure.	I need to work on this skill.
I can add and subtract multi-digit numbers.			
I can multiply multi-digit numbers.			
I know how to add decimals.			
I know how to calculate sales tax.			
I can add up a sales invoice.			
I can do money calculations.			

Part One



Job Shadowing: Costing Repair Kits

Jerry and his friend, Matt, were watching the PGA Masters tournament on Matt's large-screen TV. Before he injured his back, Jerry had played a lot of golf. Now he went out occasionally and always wore a back brace. Matt and Jerry were discussing their club's annual golf tournament to raise funds for cancer research.

"I'm in charge of the prizes this year," said Matt. "I've got most of them, but I still need 32 prizes in the 25 dollar range."

"32 different prizes for 25 bucks?" asked Jerry.

“No, they all have to be the same. They are for the players who have entered in the platinum division. They’re paying big bucks to play in the tournament, so we’d like to give them something without breaking the bank.”

“I might be able to help you out,” said Jerry. “We have a really nice car repair and safety kit that normally retails for \$49.95. Maybe we can ask our supplier to give us a better price. Let me check into it and I’ll give you a call tomorrow.”

“That would be great!” said Matt.

The next day at Swift Auto Parts Jerry went to the shelf to find the repair and safety kit. It was distributed by Ensign Parts Sales Inc. Next, Jerry looked through the Ensign catalogue and found the repair kits. There were three listed:

Basic repair kit (comes shrink-wrapped)	cost 19.50
Standard repair kit (comes in a plastic carrying case)	cost 29.50
Deluxe repair kit (comes in a quality canvas carrying case)	cost 42.50

Swift Auto Parts carried the standard repair kit; however, Jerry could see that the deluxe kit would make an excellent prize for the golfers. Jerry decided to talk to his boss, Randy.

“I’m willing to reduce my price to help out the cause,” said Randy, whose father had died of colon cancer, “but I can’t afford to lose much on it. Talk to Ensign; then give me the figures and we’ll go from there.”

Jerry telephoned Ensign and spoke to Gino. Jerry had placed a number of orders with him in the past, and he felt they had a good working relationship. Jerry told him about the golf tournament.

“The deluxe kit. That’s 42 bucks, right? Just give me a minute here,” said Gino.

Jerry waited. He could hear an adding machine in the background.

“I can sell it to you for **\$34.75**,” said Gino.

“Thanks, I’ll get back to you later today,” said Jerry.

Jerry hung up the phone. He needed to do some calculating.



JOB TASK ONE: Costing Repair Kits

You can use a calculator for this task.

- 1 How much would 32 deluxe repair kits cost at the regular price?

32×42.50

- 2 How much would they cost at the discounted price?

32×34.75



Will Randy, Jerry’s boss, pay this amount? Jerry decided to phone Matt.

“Hi Matt. I’m working on getting you a deal on a really nice repair kit. It comes in a canvas bag, and I was thinking you could have them printed with the golf club logo. The trouble is, I think they may come in at a few bucks more than 25. Can you afford it if they are say, \$30?”

“I don’t know, Jerry. I’ve got a budget of \$850. Can you do anything for that?”

- 3 How much would each kit have to cost to stay within budget?

(\$850 divided by 32, the number of kits)

Now Jerry had the price of an individual kit (\$34.75) and the amount that the golf club could pay for it _____.

4 What is the difference between these two amounts?

Jerry multiplied this number by 32. If his boss, Randy, went for the deal, this is how much he would lose on the sale.

5 How much would Randy lose on the sale?

Then Jerry had another idea. The Digby Golf Club had been running their cancer research tournament for years now, and they had a charitable number so that they could give tax receipts to donors. If Randy lost money on the repair kits, he could get a charitable tax receipt for that amount. Jerry thought this might convince Randy to go for it.

Jerry was right. Randy looked at his figures.

“So I’ll get a tax receipt for this amount?” asked Randy.

“That’s right,” said Jerry. “And Swift Auto Parts will appear on the tournament score card as one of the donors.”

“Free advertising! I can’t go wrong with that,” said Randy.

Part Two



Job Shadowing: Checking the Order

The order from Ensign Parts Sales arrived two days later. Jerry was there to receive the shipment, and he signed for five boxes from UPS. Four boxes were identical: they each held eight deluxe repair kits. The fifth box was an order to re-stock the standard repair kits for Swift.

Here is a copy of the packing slip.

*** Packing Slip ***			
			July 23 20--
Ensign Parts Sales 201 Government Road Windsor, ON N9J 2S2			
Ship to:			
Swift Auto Parts 39 Cordova Ave. City, ON L0J 1E0			
Cust. no. 2-9282A			
4	50783-02	Standard Repair Kit	29.50
32	50784-01	Deluxe Repair Kit	42.50

“Hey, that’s the wrong price!” said Jerry, and he picked up the phone to call Gino.

“Hi, Gino. It’s Jerry from Swift Auto Parts. We just received the deluxe repair kits, but I see from the packing slip that there is no extra discount.”

“Sorry about that, Jerry! I forgot to mention it to Sandy who did the packing. And I think the invoice went out this morning. Look when it arrives, just pay the price I gave you — \$34.75, right?” said Gino.

“No problem. Thanks, Gino,” said Jerry.



JOB TASK TWO: Totalling an Invoice

- 1 When the invoice arrives in the mail, what is the amount for the standard and deluxe repair kits combined?

- 2 How much is Ensign Parts Sales charging Swift Auto Parts for the deluxe repair kits, according to the invoice?

- 3 What is the correct amount for the 32 deluxe repair kits?

When Jerry looked at the amount on the invoice, he realized that Randy would lose some more money once the tax was added in.

Workplace Know-How



Wholesalers and retailers must charge their customers the Harmonized Sales Tax (HST). In Ontario, the HST is 13%. Each business is responsible for sending the tax collected to Revenue Canada.

Cash registers calculate the tax automatically, but it is good to know how to do it with a calculator.

To calculate how much tax, simply multiply the price of an item by .13 or 13%.

You can also take the price of an item and add 13%. This will give you the total cost of an item with tax included.

$$\$10 + 13\% = \$11.30 \text{ (13\% of } \$10 \text{ is } \$1.30)$$

For every dollar you spend on an item, you have to pay an extra 13 cents in taxes.

To calculate the total of an item including the tax, multiply the price by 1.13.



JOB TASK THREE: Calculating Sales Tax

- 1 How much will the 32 deluxe repair kits at \$34.75 each cost including the tax?
 $32 \times 34.75 \times 1.13$.

- 2 How much will Randy lose now? Subtract \$850 from the total cost of 32 repair kits plus tax.



OVERTIME ACTIVITY: Completing Invoices

- 1 Complete the invoices on the next pages. Fill in the total sales amounts, the HST and the total amount due. Add \$10.00 for a shipping and handling fee.

Ensign Parts Sales

INVOICE

400 Riverpark Ave.
Windsor, ON, N8N 3A4
Phone 226-679-4172

INVOICE #[100]
DATE: JULY 19, 2010

SHIP TO:
Swift Auto Parts
39 Cordova Ave.
Hamilton, ON, L0J 1E0
Phone 905-232-7466 Fax 902-232-7467

COMMENTS OR SPECIAL INSTRUCTIONS:

QUANTITY	DESCRIPTION	UNIT PRICE	TOTAL
4	Passenger Side Mirror Part # FD56ER	35.61	
12	Nifty XTREME floor mats, set of 2, black	75.73	
		SUBTOTAL	
		SALES TAX	
		SHIPPING & HANDLING	
		TOTAL DUE	

Make all cheques payable to Ensign Parts Sales

Thank you for your business!

Downtown Auto Parts

INVOICE

291 Government Road
Windsor, ON, N8N 4B1

INVOICE #[100]
DATE: JULY 19, 2010

SHIP TO:
Swift Auto Parts
39 Cordova Ave.
Hamilton, ON, L0J 1E0
Phone 905-232-7466 Fax 902-232-7467

COMMENTS OR SPECIAL INSTRUCTIONS:

QUANTITY	DESCRIPTION	UNIT PRICE	TOTAL
6	Bulldog Remote Starter LS2000	126.80	
9	Covercraft Bench Seat Pet Pad, Grey	52.14	
3	Universal Pet Barrier, Black, 45" H X 65" W adjustable	80.38	
		SUBTOTAL	
		SALES TAX	
		SHIPPING & HANDLING	
		TOTAL DUE	

Make all cheques payable to Downtown Auto Parts

Thank you for your business!

Performance Review

In this chapter you have worked on the numeracy skills necessary for work. How do you think you did? Use the chart below to reflect on your improved ability to use numeracy skills for work.

Essential Skill	Exceeds Expectations	Meets Expectations	Needs Additional Training	LBS	ES
Numeracy					
Money Math					
I can total a sales invoice.				3	2
I can calculate sales tax.				3	2
Number Concepts					
I can multiply decimals.				3	2
I can add and subtract multi-digit numbers.				2	1
I can multiply multi-digit numbers.				3	2

CHAPTER 3

Maria Uses Math

Do you have the skills necessary to do math at work?

Employability Skills	I have this skill.	I am not sure.	I need to work on this skill.
I can schedule my activities and appointments.			
I can correctly estimate the time needed for my work and activities.			
I can keep track of and calculate my driving mileage.			
I can add up my expenses.			



Job Shadowing: Scheduling

Maria’s cell phone alarm woke her at 6 am. She sat up and switched on her bedside light.

“What are you doing? Are you okay?” asked her husband, Vince.

“I’m fine!” said Maria.

“It’s the middle of the night,” Vince protested.

“It’s after six, and you’d better shut your eyes because I need to turn on the room light.”

Vince grumbled and stuck his head under the pillow. Maria rummaged through her dresser drawer and then shut off the light.

By 6:30 Maria was showered, dressed and eating breakfast. She had her planner open on the table beside her.

Tuesday 20 June	
7:00 AM	
7:15	
7:30	
7:45	
8:00 AM	Doris Langly, 1035 — 41 Tulip Court
8:15	
8:30	
8:45	
9:00 AM	Bob Hines, 44 Redburn Street
9:15	
9:30	
9:45	
10:00 AM	Freda Gregson, 25 Mill Road
10:15	
10:30	
10:45	
11:00 AM	Dentist with Sophia
11:15	
11:30	
11:45	
12:00 PM	
12:15	
12:30	
12:45	
1:00 PM	Eva Tomasso, 87 James Street
1:15	
1:30	
1:45	
2:00 PM	Mrs. Mallory, 29 Rose Heights Ave N
2:15	
2:30	
2:45	
3:00 PM	Bruno Gentile, 1204 — 41 Tulip Court
3:15	
3:30	
3:45	
4:00 PM	
4:15	
4:30	
4:45	
5:00 PM	

What a day! Maria thought as she munched on her toast.

First I've got to drive over to the east side of the city for Doris. Then a few blocks away to get to Bob Hine's place. That's not too bad.

Maria munched some more and took a sip of tea.

That's going to be tight, she thought. I've got to finish at Redburn Street and then drive over to Mill Road for Freda. I better phone her a little later and tell her I may be a few minutes late.

But I can't be late! I've got to pick up Sophia and take her up to the dentist's. Well, I should have enough time after that. Dr. Zhang said the wisdom teeth should be a straightforward extraction, about 40 minutes.

I don't know what I'm going to do if it takes any longer. Eva Tomasso is so demanding! If I am one minute late, she will be on the phone to my supervisor, Beverly — I know it!

Maria sighed and poured some more tea into her cup. Let's see what the rest of the afternoon looks like, she thought.

Mrs. Mallory is a new client. I don't want to be late for her. Hmm, James Street to Rose Heights isn't too bad. Wait a minute! That's Rose Heights Avenue North! How will I ever get there on time?

Great. After that I'm across the city again to Tulip Court Retirement Home. This day is going to be impossible!



JOB TASK ONE: Estimating Time

Maria decided that she needed to estimate the time she would be spending with clients and the time she would take to travel between appointments. Then she would know whether or not she could manage her day as planned.

Help out with Maria's schedule by filling in the times below.

- ▶ Fill in the times in the space provided.
 - ▶ The scheduled times in Maria's planner tell you when she should arrive at her appointments. Use a tick mark (✓) to indicate if you think that she will be on time.
 - ▶ Maria planned to leave the house at 7:40 am.
- 1 It would take about 20 minutes (or 25 if the traffic was bad) to drive to 41 Tulip Court. That would get her there at about _____. On time? ___ Late? ___
 - 2 Maria would spend about 45 minutes with Doris. She would be finished at about _____. On time? ___ Late? ___
 - 3 It would take 15 minutes to get to Redburn from there. She would probably spend at least 50 minutes with Bob. He so rarely received any visitors, Maria always tried to spend a few extra minutes with him. She would be finished at Bob's around _____. On time? ___ Late? ___
 - 4 It would take Maria another 15 minutes to drive to Mill Road. She planned to spend 45 minutes with Freda. Maria would leave Freda's around _____. On time? ___ Late? ___
 - 5 Maria needed just 10 minutes to drive home to pick up Sophia and then another 10 to get to the dentist's. Just in case they had to wait, Maria planned for an hour at the dentist and another 10 minutes to drive home. If the appointment actually took 50 minutes, she would arrive back home at about _____.
 - 6 After her busy morning, Maria decided that she would relax at home and take a full hour for lunch. Does she have time for a full hour before her next appointment? ___ How much time does she have for lunch? _____
 - 7 Fortunately, Eva's house on James Street was not far from Maria's place, and she could be there in about 5 minutes or at _____. On time? ___ Late? ___
 - 8 Rose Heights Avenue North would be about a 20 minute drive. In order to arrive there at 2 pm, Maria needed to leave Eva Tomasso's home at _____.
 - 9 A first visit often took at least an hour. If she took an hour and ten minutes with Mrs. Mallory and needed 15 minutes to drive back to Tulip Court, when would Maria see her client, Bruno? _____ On time? ___ Late? ___

Estimating Time



When you have a busy schedule like Maria’s, sometimes you need to do more than just book your appointments.

- You also need to plan for travel time. Has Maria given herself enough time to travel to her various appointments?
- It also takes time getting in and out of the car, using stairs and elevators and even waiting for people, particularly the ill and the elderly, to answer their doors. Has Maria allowed enough time in her schedule for small extras that add up?
- Has Maria built in any **contingency** time? Contingency is a possible event or circumstance that cannot be predicted with any certainty. It is something that may happen or may not happen. For example, Maria is doing a lot of city driving this day. One contingency she should allow for is heavy traffic. Has Maria made a contingency plan for heavy traffic? That is, has she allowed extra time just in case she gets stuck in traffic? As well, Maria knows that Bob loves to talk and Freda can be very slow if she’s having a bad day. Has Maria built in any extra time if these clients take a little longer than usual?



JOB TASK TWO: Time Management

Answer the following questions, using Maria’s time estimates. Don’t forget the “Estimating Time” toolbox information when answering.

- 1 Do you think Maria will make it to all her appointments on time? Why or why not?

- 2 What time do you think Maria should leave her house? Why?

3 Will Maria be on time for Sophia's dentist appointment?

4 Will Maria make it to Bruno's appointment on time? _____



JOB TASK THREE: Scheduling

After doing some figuring, Maria realized that she had some problems in her schedule. Read the extra notes about her day below and see if you can help Maria manage her time. Use her day planner to fill in the needed changes. Make sure you give Maria enough time for "contingencies"!

- ▶ Doris Langly was always up early in the morning and probably wouldn't mind if Maria came a little earlier. Use the planner to re-schedule Doris's appointment.
- ▶ Maria was going to help Bob Hines with his shower. His physiotherapist was arriving at 10 am and Bob liked to be clean and tidy when she arrived.
- ▶ Freda Gregson could sometimes be very slow if it was one of her bad days. Maria liked to take her for a walk if they had time. Or, if Freda was not feeling well, Maria would encourage her to sit on her front porch for some fresh air.
- ▶ Her daughter, Sophia, told Maria that she (Sophia) could take the bus to the dentist's office and meet her mother there. Maria knew she would need to drive Sophia home because she would still be feeling the effects of the local anaesthetic.
- ▶ Eva Tomasso would be expecting her at 1 pm. She would not mind if Maria was a few minutes early, but she would not like her to be late.
- ▶ Mrs. Mallory, the new client, has her first appointment at 2 pm. Maria never changed the time of a first appointment if she could help it.
- ▶ Bruno Gentile is a very easy-going client.

Maria would finish up with Bruno around _____. She would definitely hit heavy traffic on her way home and the drive would take her about 25 to 30 minutes. About what time will Maria arrive home? _____

Tuesday 20 June	
7:00 AM	
7:15	
7:30	
7:45	
8:00 AM	Doris Langly, 1035 — 41 Tulip Court
8:15	
8:30	
8:45	
9:00 AM	Bob Hines, 44 Redburn Street
9:15	
9:30	
9:45	
10:00 AM	Freda Gregson, 25 Mill Road
10:15	
10:30	
10:45	
11:00 AM	Dentist with Sophia
11:15	
11:30	
11:45	
12:00 PM	
12:15	
12:30	
12:45	
1:00 PM	Eva Tomasso, 87 James Street
1:15	
1:30	
1:45	
2:00 PM	Mrs. Mallory, 29 Rose Heights Ave N
2:15	
2:30	
2:45	
3:00 PM	Bruno Gentile, 1204 — 41 Tulip Court
3:15	
3:30	
3:45	
4:00 PM	
4:15	
4:30	
4:45	
5:00 PM	

**Job Shadowing: Gas Mileage Expenses**

It was Friday evening and Maria was cutting up eggplant for ratatouille. Vince was at the kitchen table looking over the household bills.

“If I didn’t know better, I’d say that Petro Canada is in the shoe business,” said Vince.

“Shoe business? What do you mean?” asked Maria.

“I mean, the only time your credit card goes up like this, you’ve been buying shoes!” said Vince.

Maria stopped chopping and looked over Vince’s shoulder at the Visa bill.

“Wow!” she said, “I had no idea I was spending so much on gas.”

**JOB TASK FOUR: Adding up Expenses**

- 1 Help Maria calculate how much money she spends on gas in an average month. Use the Visa Statement below and add up all the gas purchases.

Transactions since your last statement

Ref. #	Trans. Date	Details	Amount
Ms. Maria Furletti — 2142 533 071 675 910			
001	May 3	Petro Canada Guelph, ON	46.01
002	May 4	Walmart Guelph, ON	76.34
003	May 11	Pet Value #509 Guelph, ON	25.67
004	May 13	No Frills Grocery #208, Guelph, ON	75.09
005	May 13	Boston Pizza #413, Guelph, ON	54.05
006	May 20	Petro Canada Guelph, ON	74.97
007	May 28	Petro Canada Guelph, ON	56.43
008	May 29	Shopper’s Drug Mart 0731, Guelph, ON	88.29
009	May 30	Sears Canada, Guelph, ON	94.26

“I thought you got paid for mileage,” said Vince.

“Well I do, sort of,” said Maria.

“What do you mean?”

“I get 40 cents a kilometre after the first 20 kilometres. So if I drive, say, 30 kilometres, I will be paid mileage for 10 kilometres. 10 kilometres at 40 cents a kilometre is four bucks.

“Huh,” grunted Vince.

Maria and Vince had been married over 20 years, and she knew exactly what “huh” meant.

“It’s better than nothing!” she said defensively.

“It’s not much better than nothing, especially when you consider the wear and tear on the vehicle,” he said with a smile.

Maria sighed. “You’re right. I barely break even! Look, I’ll show you the record of my mileage this month.”

Vehicle Mileage Log

Beginning Date	
----------------	--

Date	Odometer Reading		Kilometres Travelled	Details (Client ID)	Total Mileage over 20 kms.
	Beginning	Ending			
May 3	89,323	89,371		0321, 0098, 0105, 0210, 1034, 0658	
May 4	89,380	89,420		0086, 1090, 0495, 0023	
May 5	89,431	89,475		0625, 0083, 0591, 1008	
May 6	89,491	89,531		0086, 1090, 0495, 0023	
May 7	89,542	89,590		0321, 0098, 0105, 0210, 1034, 0658	
May 10	89,622	89,670		0321, 0098, 0105, 0210, 1034, 0658	
May 11	89,681	89,721		0086, 1090, 0495, 0023	
May 12	89,734	89,782		0625, 0083, 0591, 100	
May 13	89,793	89,854		0086, 1090, 0495, 0023	
May 14	89,863	89,911		0321, 0098, 0105, 0210, 1034, 0658	
May 17	89,936	89,984		0321, 0098, 0105, 0210, 1034, 0658	
May 18	89,992	90,032		0086, 1090, 0495, 0023	
May 19	90,038	90,082		0625, 0083, 0591, 1008	
May 20	90,089	90,129		0086, 1090, 0495, 0023	
May 21	90,138	90,186		0321, 0098, 0105, 0210, 1034, 0658	
May 25	90,234	90,290		0086, 1090, 0495, 0023, 0321, 0098,	
May 26	90,298	90,345		0625, 0083, 0591, 1008 0105, 0210,	
May 27	90,362	90,411		0086, 1090, 0495, 0023 1034, 0658	
May 28	90,422	90,470		0321, 0098, 0105, 0210, 1034, 0658	
Total Kilometres				Total Allowed Mileage	
Reimbursement Amount (at .40/km)					

“I see what you mean,” said Vince. “It’s good that you are keeping track of your mileage because you will be able to claim it as an expense on your taxes this year.”

Maria nodded and went back to chopping vegetables. Vince looked at her but did not say anything. He noticed that Maria had not seemed quite so happy about work lately. Could she be tiring of her job already? Vince was patient and he knew that eventually Maria would talk to him about it.

“You know what, Vince?” said Maria as she chopped the onions. “I love my work. I like the people and I love helping them. But I really can’t stand Home Sweet Homecare and Beverly Lake.”

“Huh,” said Vince. It was a different ‘huh’ this time, and Maria was encouraged to continue.

“The trouble is that without a PSW certificate, I am pretty much stuck working for places like Home Sweet Homecare.” Maria smashed the garlic with the side of her knife. “I think I’ll drop by the college next week and see what’s involved in getting my certificate.”

“Great idea,” said Vince. “In the meantime, I think that you need to submit an expense form for your mileage this month.”



JOB TASK FIVE: Calculating Mileage

Help Maria figure out her monthly mileage. Fill in the Vehicle Mileage Log on the next page. You can use a calculator for this activity.

- 1 What is Maria’s mileage for each day? What is the mileage over 20 km for each day?
- 2 What is the total mileage for the month? What is the total mileage over 20 km for the month?
- 3 Maria receives \$0.40 for every km over 20. How much will she receive from her employer for her mileage costs?
- 4 Is Maria breaking even? Compare her gas costs for the month to her reimbursement? What is the difference?



OVERTIME ACTIVITY: Learning about Time Management

When you have a lot of back-to-back appointments, try to include a little extra time in between. This way, if you are behind on one appointment, it will not make you late for the rest of your schedule.

For more information on time management and scheduling, check out the following websites:

- 1 Take the Time Management Assessment at:
www.mindtools.com/pages/article/newHTE_88.htm
- 2 Learn some Time Management Assessment Tips at:
www.timemanagementhelp.com/tips.htm
- 3 The Learning Edge has a scheduling activity in Issue 6.
For additional practice, check out their website.
<http://www.thewclc.ca/edge/issue6/index1.html>

Performance Review

In this chapter you have worked on the numeracy skills necessary for work. How do you think you did? Use the chart below to reflect on your improved ability to use numeracy skills for work.

Essential Skill	Exceeds Expectations	Meets Expectations	Needs Additional Training	LBS	ES
Numeracy					
Scheduling Math					
I can manage my time to schedule activities and appointments.				2+	2
Money Math					
I can add up my expenses.				2	1
I can calculate a mileage charge.				3	2
Number Concepts					
I can add, subtract and multiply whole numbers.				2	1
I can multiply a decimal.				3	2
Other Essential Skills					
Document Use					
I can fill in a mileage log.					2
I can fill in a day planner.					1
Thinking Skills — Job Task Planning and Organizing					
I can plan and organize my schedule.					2

CHAPTER 4

Keith Uses Math

Do you have the skills necessary to do math at work?

Employability Skills	I have this skill.	I am not sure.	I need to work on this skill.
I can work with simple ratios.			
I can calculate the area of a rectangle in square feet.			
I can measure in feet and inches.			
I can calculate the square footage of a room.			
I can measure, using a scale drawing.			
I can multiply two-digit numbers.			

Part One



Job Shadowing: Mixing Concrete

Straight Path Construction has been working on a big job for a couple of months. They have been replacing sewer pipes, and now they are ready to repave the sidewalk stones that have been damaged due to the drilling. Keith and Jordan have been working on sidewalks all week. Now they have a single sidewalk slab left to do, but they have run out of concrete.

“Just mix enough for the slab by hand,” said Mario.

“Sure,” said Jordan.

Keith looked over at Jordan. He sure hoped that Jordan knew how to mix concrete because he had never done it before.

“Don’t worry, it’s pretty easy once you’ve done it a few times,” said Jordan. “The trickiest part is the water.”

“All you have to remember is the ratio,” he explained to Keith. “One part cement, to two parts sand, to three parts gravel. One, two, three and bingo, you’ve got concrete.”

Jordan opened a bag of cement.

“One of these bags has about eight shovelfuls of cement,” he said, “So we’ll use about half, that’s four shovels.”

Keith scooped four shovelfuls into the wheel barrow.

“Okay, so now we need eight shovels of sand,” said Jordan.

“How do you know that?” asked Keith.

“It’s the ratio,” Jordan said. “In this case, the one part cement is four shovels. So if one part is four, then two parts is 4×2 or 8. Easy, right?”

“I get it! So we’ll need three parts gravel, and 4×3 is 12. We’ll need 12 shovels of gravel.”

“You got it,” said Jordan.



JOB TASK ONE: Mixing Concrete

Help Keith mix concrete. Read the information below to learn the correct ratio of cement to sand to gravel. You might find it easier to calculate if you show it in a chart. Fill in the chart on the following page with your answers to the questions.



You can easily make your own concrete mix in a wheelbarrow, using 1 part cement, 2 parts sand and 3 parts gravel. Mix it all together before adding water. A smaller spade or shovel is easier to work with than a bigger one.

Start pouring water in and mixing. Add a little of the water at a time. Mix with the spade from underneath and fold over. Keep doing this and adding the water until it is a uniform consistency. The wet concrete is now ready to pour.

(from: www.buideasy.com/newplan/easylist/concrete_mix.html)

- 1 If Keith uses 6 shovelfuls of cement, how much sand and gravel will he need?
- 2 If Keith uses 18 shovelfuls of sand, how much cement and gravel will he need?
- 3 If Keith uses 12 shovelfuls of gravel, how much cement and sand will he need?
- 4 If Keith uses 3 shovelfuls of cement, how much sand and gravel will he need?

	Cement	Sand	Gravel
	1	2	3
1.	6		
2.		18	
3.			12
4.	3		

Part Two



Job Shadowing: Measuring

Keith’s supervisor, Mario, asked Keith to work at a different construction site for the rest of the week.

“We need to put a roof on a medical building,” he said to Keith.

Keith was a little nervous because he had never done any roofing. He saw Tony at the site and waved to him. Keith hadn’t worked with Tony for a few weeks.

“Hi Tony, how are you?” asked Keith.

Tony and Keith talked for a few minutes, and then Tony said, “We have to replace some plywood on the west side of the roof before we can shingle.”

“Uh, okay.” Keith paused. “Um, Tony? I’ve never done any roofing. I’m not sure what to do.”

Tony slapped him on the back.

“Don’t worry! I’ll take care of you.”

Before they climbed onto the roof, Tony drew Keith a diagram.

“This is the side of the roof that needs the new plywood,” he said, stabbing a large rectangle with a pencil. “The length is 32 feet. The width is 24 feet.”

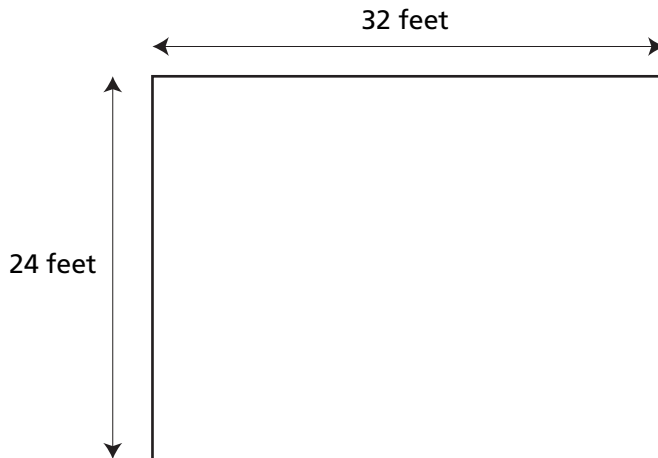

“Okay,” said Keith, eyeing the rectangle.

“There was a roof leak up at the top in the north-west corner, here,” he said, drawing an X on the rectangle.

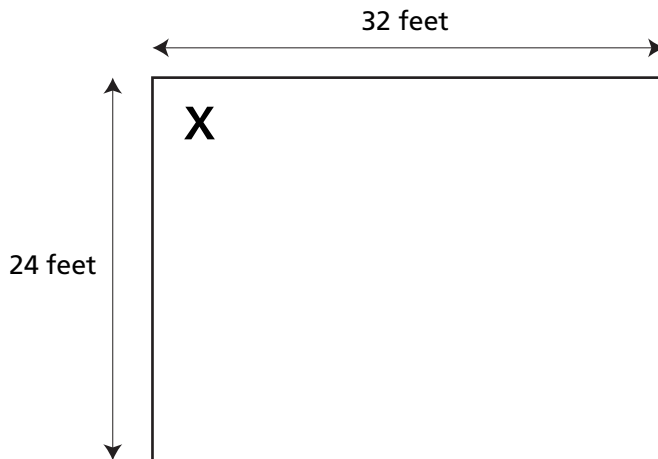

“Right. A leak in the north-west corner,” said Keith. He looked from the diagram to the roof. So far, so good, he thought to himself.

“We have to replace all of the water-damaged plywood,” said Tony. “So that’s two rows of plywood along the west side. Plus, the plywood needs to be replaced all along the eavestrough.”

“Okay,” said Keith.

“Got it? Good. So how many sheets of plywood are we going to need?”

“Uhhh,” said Keith.

Tony laughed. “You think about it while I go and get coffee.”

Keith looked at the diagram that Tony had made with the side of the roof measuring 24×32 feet. Keith also knows that plywood roofing sheets are 4×8 feet.

“Okay,” Keith muttered to himself. Tony says that we need to replace two rows of plywood along the west side of the roof. So I’ll draw in 2 rows.

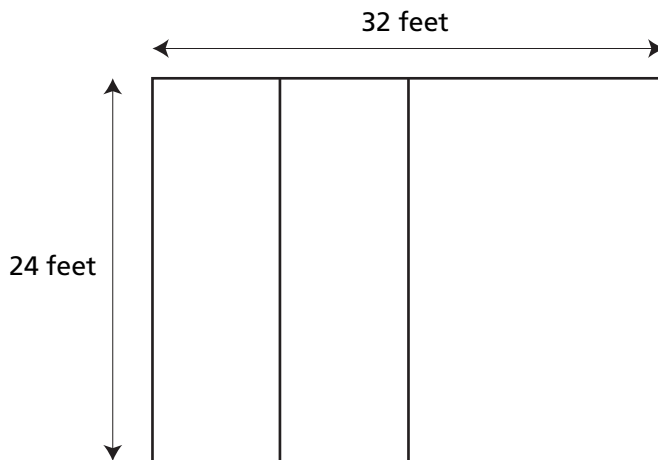

“All right. And we also need to replace all of the plywood along the eavestrough — that’ll be at the bottom,” said Keith and he drew a line there.

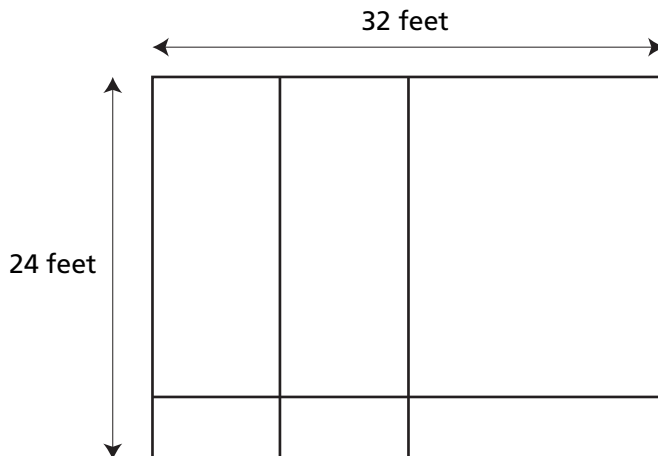

“Hey!” said Keith as he looked at his diagram. “I already have two pieces of plywood drawn in this bottom left-hand corner.”

Keith studied the diagram some more. “Since I have two boards on my diagram already, I think I’ll figure out how many I need along the bottom first.”

Follow Keith's math as he works out the answer.

The bottom edge or length of the roof measures 32 feet.

There are two boards measuring 8 feet each already in the bottom left corner.

$8 + 8 = 16$, so 16 feet is already covered with plywood.

$32 - 16 = 16$, so that means that there are 16 feet left to cover with plywood.

“That’s two more sheets of plywood!” said Keith and he drew them in.

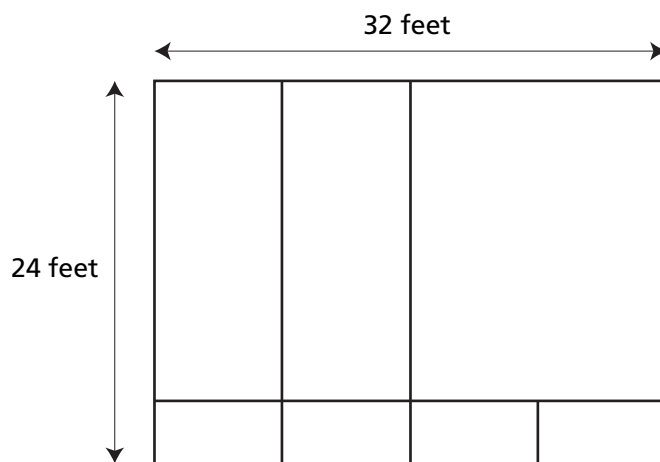

“So four sheets of plywood measuring 8 feet each fit into 32 feet,” Keith observed.

That is the same as saying $4 \times 8 = 32$.

“Let’s see...the width of the roof measures 24 feet and the plywood measures 4 feet along its sides,” said Keith. “That means that I need to know how many 4 foot boards will fit into 24 feet.

That is the same as saying $4 \times \underline{\quad} = 24$.

“I know the answer to that,” said Keith. “There will be six boards going down the roof in each row along the west side.”

Keith drew his final diagram. “Now all I have to do is count the sheets of plywood!”

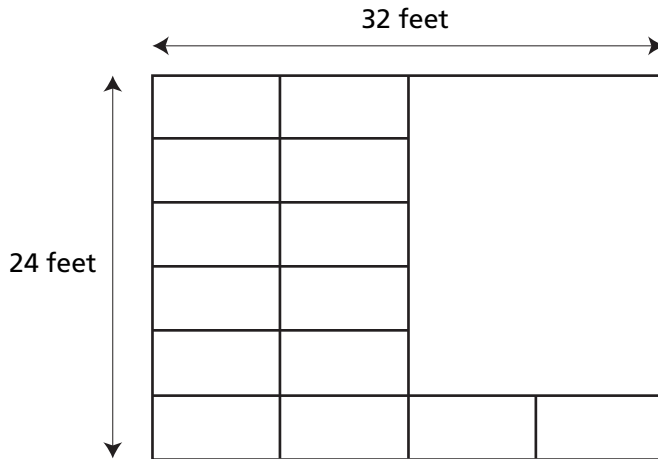

“Have you figured it out yet?” asked Tony.



How many sheets of plywood do they need for the roof?

Diagrams can be very helpful for measurement. Keith used diagrams to help him figure out how many sheets of plywood he needed for the roof. By the end of the summer, Keith had done quite a number of roofs. He no longer needed to use diagrams because he could work it out just using the math.



JOB TASK TWO: Roofing Measurement

Here are the roofs that Keith was working on. On each of these roofs all of the plywood needed to be replaced. Don’t forget that when you are roofing the plywood always goes the same way, with the long edge of the plywood on the horizontal.

- 1 How many sheets of plywood would you need for this 20 by 40 foot house? Draw on the diagram to help you figure it out the same way Keith did.

_____ sheets of plywood.

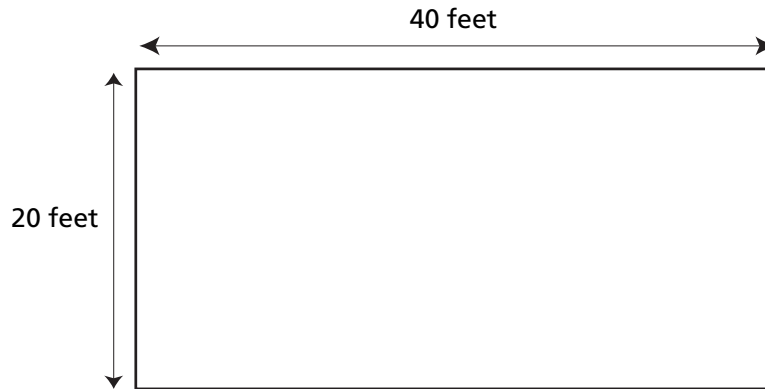

- 2 How many sheets of plywood for a home measuring 40 feet by 56 feet?

_____ sheets of plywood.

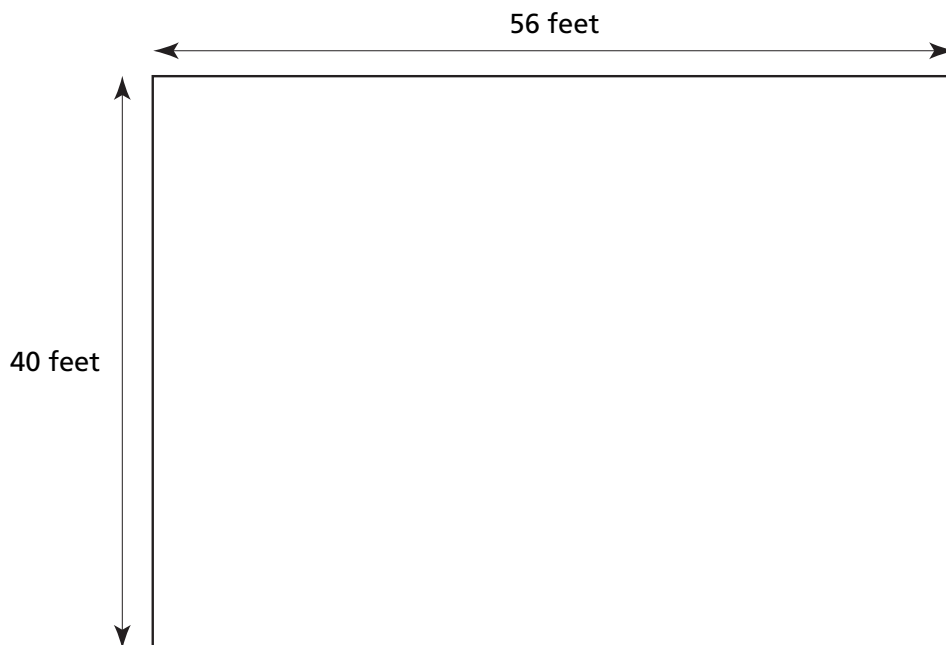

3 How many sheets of plywood for a storage building measuring 48 feet by 64 feet?

_____ sheets of plywood.

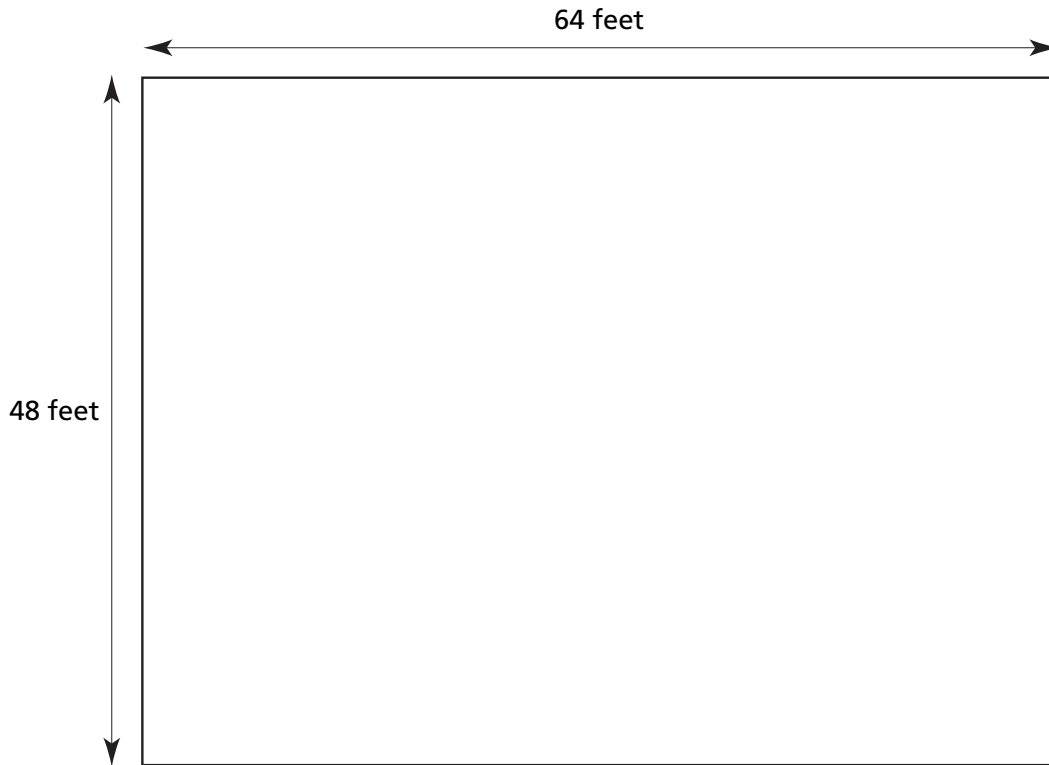

4 For the last problem, try drawing your own sketch. Don't worry, neatness doesn't count. The house measures 24 feet by 56 feet. How many sheets of plywood would you need to cover the roof?

Now add on a two car garage which measures 24 feet by 24 feet. How many more sheets of plywood would you need?

Workplace Know-How



If you are going to be working on roofs or any worksite which includes a risk of falling, you will need to take **“Fall Arrest Training.”** The Construction Safety Association of Ontario says that falls are the leading cause of fatal accidents in the construction industry. Fall protection training is required to work in the construction industry. For more information on this important training check out the following website:

www.csa.org/t.tools/t14.fallprotection/index.cfm

Employers will often pay for their staff to take this training as well as provide the necessary safety harnesses.

Employers not enforcing the use of proper safety equipment by staff when employees are working on roofs are violating Ministry of Labour regulations.

If you wish to take this training before your first job, a good place to start is by talking to your local Job Connect office. Community colleges often offer this training on a regular basis.

Keith decided that he would look up roofs in the building code. He was surprised to see that measurements are given in metric.

“Why don’t we use metric when we measure?” Keith asked Tony.

Tony shook his head and shrugged his shoulders.

“The trouble is, the wood is measured in inches and feet. Sometimes we have to convert to metric and vice versa.”

Metric and Imperial Measurement



Carpentry and plumbing still use the imperial (feet and inches) measurement system. Lumber, siding, piping ...are all measured in feet. Building plans are also usually in feet. Keeping a copy of a simple conversion chart is useful for those working in construction. Contractors will normally have a calculator which converts from imperial to metric.

The following website converts either to or from metric

www.metric-conversions.org/measurement-conversions.htm



OVERTIME ACTIVITY: Measuring Area



Do you know how to calculate the area for buildings? You need to multiply the length by the width. Your answer will be the area in square footage.

You can use a calculator for the next activities if you wish.

1 Hardwood Flooring

You are installing new flooring in a room **20 feet by 10 feet**. The entry way in this room is 4 feet by 5 feet. You need to purchase tile for the entry way and hardwood flooring for the rest of the room. In order to calculate how much flooring is needed, you must first calculate the square footage (**length × width**).

Use the diagram below to:

- a) Calculate the total square footage.

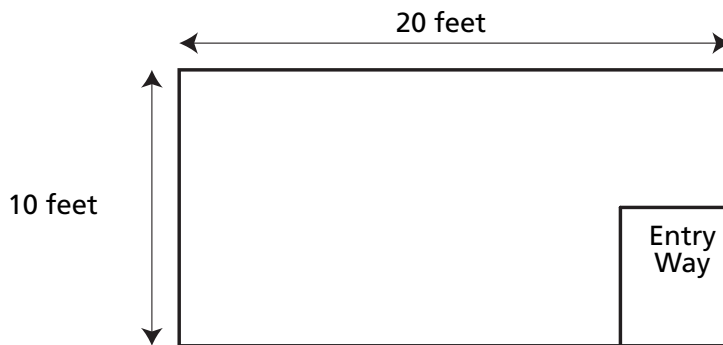

- b) Calculate the square footage of the entry way.

- c) Decide how many square feet of hardwood flooring you will need to buy. Don't forget to subtract the entry way.

- d) Decide how many square feet of tile you will need to buy.

2 Paint Coverage

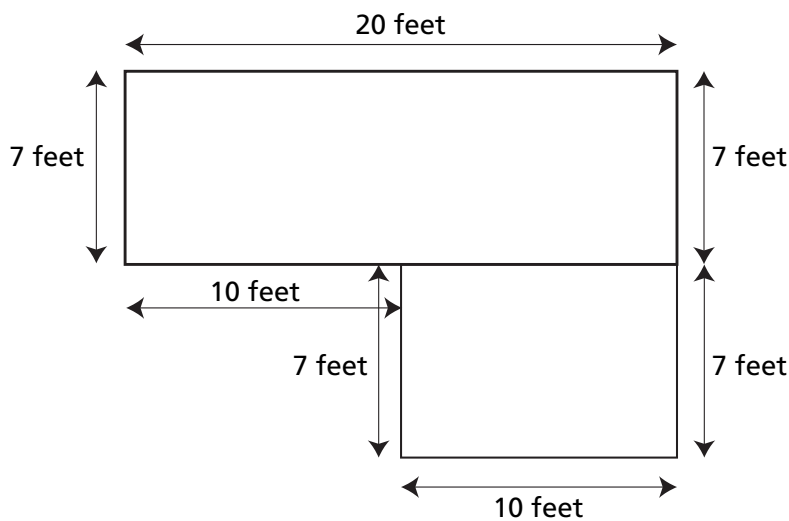

Have you ever struggled to figure out the amount of paint needed to cover a room? Length X width will give you the area of a rectangle (like a roof) but you need more to paint a room because you have to consider the height as well.

- a) Using the diagram above, add the lengths of all the walls.

- b) Multiply the total length of the walls by the height of the ceiling. Use 8 feet as the ceiling height.

- c) You now have the room's square footage for painting. This room also has two average size windows and two doors. Subtract 15 square feet for each window and 20 square feet for each door. **What is your new total?**
-

- d) One gallon of paint will typically cover 350 square feet. Divide your paintable wall area by 350. The answer tells you how many gallons of paint you will need. If your remainder is less than .5 you will only need one or two extra quarts. Over .5, you will need an additional gallon.

How many gallons do you need to buy for one coat of paint?

Performance Review

In this chapter you have worked on the numeracy skills necessary for work. How do you think you did? Use the chart below to reflect on your improved ability to use numeracy skills for work.

Essential Skill	Exceeds Expectations	Meets Expectations	Needs Additional Training	LBS	ES
Numeracy					
Measurement and Calculation Math					
I can calculate amounts by doubling and tripling.					2
I can calculate the area of simple shapes.					2
I can calculate areas of walls, taking into account windows and doors for painting.					3
I can calculate areas of floors for flooring.					3
Number Concepts					
I can add, subtract, multiply and divide simple whole numbers.				2	1
I can show comparison between two or three simple ratios.				3+	2
I can multiply two-digit numbers.				3	2
Other Essential Skills					
Document Use					
I can make measurements from scale drawings.					2